

TAITO

TOP LANDING™

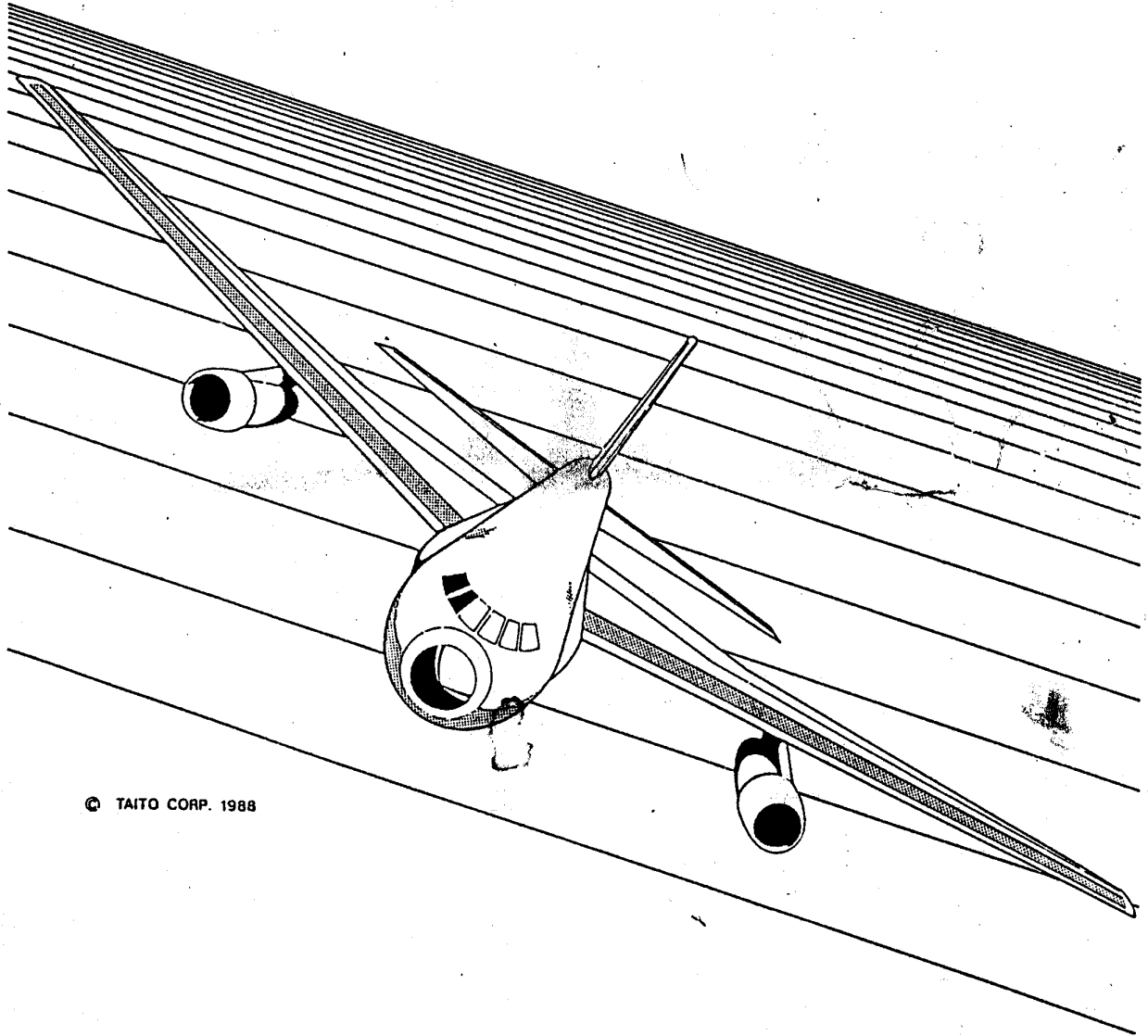

© TAITO CORP. 1988

SERVICE INSTRUCTIONS AND PARTS CATALOGUE

TAITO CORPORATION

G25 00482A

TOP LANDING

Specifications:

1. Power Supply	100 VAC (50/60 Hz)
2. Power Consumption	125 W
3. Play Pricing	1 Play - 1 Coin (Adjustable)
4. TV Monitor	20-inch Color
5. Dimensions	Width : 600 mm Depth : 975 mm Height: 1760 mm
6. Weight	Approximately 100 Kg

★ The specifications and appearance may be changed for improvement.

Table of Contents:

1. Overview Description	1
2. Installation	2
3. Handling Care	3
4. Safety Measures	3
5. Central Control	4
6. Headphone Control	4
7. Switching Regulator	5
8. Adjustments of Color Video Monitor	6
9. Play Instructions	9
10. Test Mode	14
11. Adjustments of Main PC Board	15
12. How to Remove Control Panel	16
Parts Catalog	17
Cable Block Diagram	

2. Installation

- Avoid rough handling in transportation; the picture tube is fragile.
- This machine is designed for "indoor" use.
So install the machine indoors only.
- Install the machine on flat-surfaced floor (made of concrete, etc.) and provide suitable space around it. Do not install the machine in locations with vibrations.
- Do not install the machine in locations exposed to sunlight or excessive heat to avoid the environmental temperature rise.
Also, do not install the machine at places where it is humid and/or dusty.

- Do not install the machine in dangerous places in view of disaster prevention, fire alarm equipment, etc.

- Never fail to connect the "ground terminal" of the machine and the "ground line" of the power supply cord.

- Before turning on the power switch!
The screws for fastening the parts may be loosened by vibrations, etc. in transportation. Make certain that the PC board is correctly attached and the connectors are perfectly plugged.
- Plug the power cord plug into the outlet and turn on the power switch. Before this, make sure the power supply and the current capacity.
- In case that any malfunction occurs after turning on the power:
First, turn off the power switch, and check the power supply and each output by referring the handling care.
This machine does not work normally unless the proper power supply voltage is supplied.

3. Handling Care

- This game uses microprocessors and other ICs for long stable performance life, however, as with sophisticated electronic equipment, certain precaution must be observed to avoid damage.
- Do not attempt to service with ordinary testing equipment, since the internal voltage of testing equipment may cause damage to the circuitry.
- Never connect or disconnect any of connectors of the PCB set when the power is on.
- As higher voltages exist in the video monitor, extra care must be taken when inspecting and adjusting the video monitor.
- Do not use fuses with other current capacity than specified. If the fuses with the specified current capacity are blown, check the power unit.

[Inside of Cabinet]

[Outside of Cabinet]

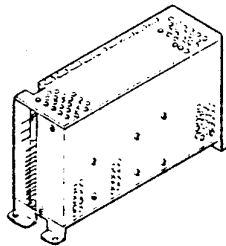

Switching Regulator
5A

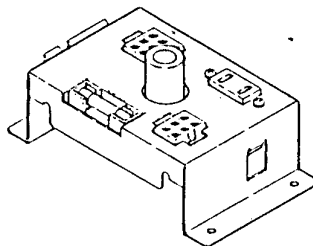

Connector Box
3A

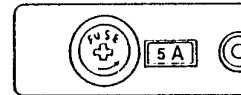

Main Fuse
5A

4. Maintenance

- Although this machine has been designed basing on the good safety standards, some trouble may occur in a long period. Therefore, it is necessary for the machine owner and operation manager to take daily checking to make sure that the safety condition of the machine is well kept.

5. Central Control

☆ The central control is located inside the rejector door.

- Sound Volume Control Knob
Turning the knob clockwise increases the sound volume.
Adjust it to suit the environment of the location.
- Service Switch
By pressing this switch, the number of credits can be increased without operating the coin counter.

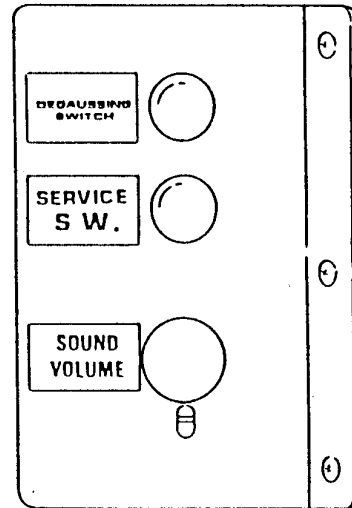

- Degaussing Switch
Color aberration may occur depending on the setting condition of the machine. In that case, use the degaussing switch.
Use this switch after an interval of 10 minutes when once used.

6. Headphone Control

☆ By using your headphone, you can enjoy playing the game with hearing the powerful sounds.

- Phone
The headphone with a 2.5-diameter terminal can be connected.
- Volume
This is the sound volume control for the headphone. Turning this "VOLUME" clockwise increases the sound volume.



7. Adjustments of Switching Regulator

- ★ If the line voltages are set at higher values than specified, the ICs may be broken. So use extreme care for this.
- When checking the output voltages, turn the potentiometer shown below slowly clockwise or counterclockwise by using a ⊖ small screw driver by referring to the cable block diagram.

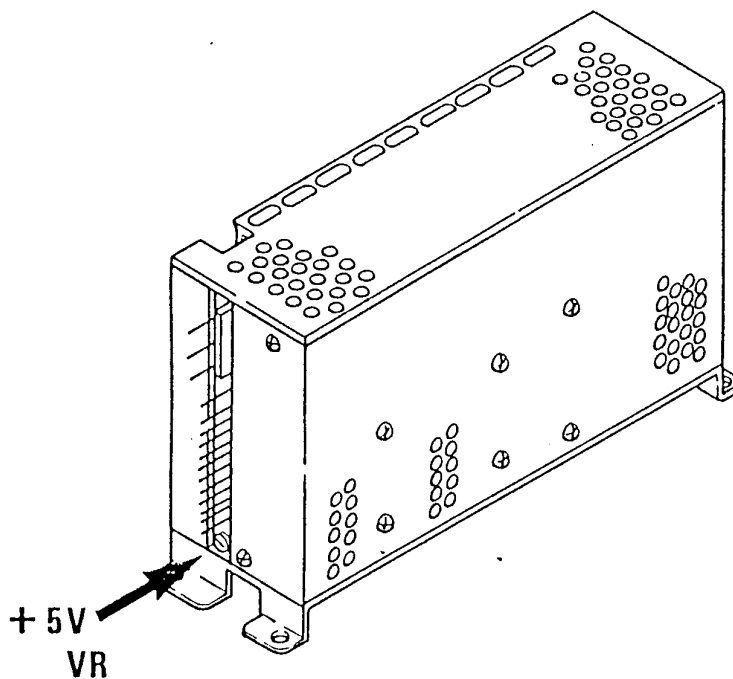

- +5V VR

This is the potentiometer of adjusting the voltage of the +5 VDC line. By this potentiometer, the voltage can be changed $\pm 10\%$. This voltage is preset at +5V.

Note: The voltages of +12 VDC and -5 VDC are fixed.

8. Adjustments of Color Video Monitor

• The video monitor is properly adjusted before shipping, however, according to the condition of location, some adjustments may be required. In such case, refer to the following explanation.

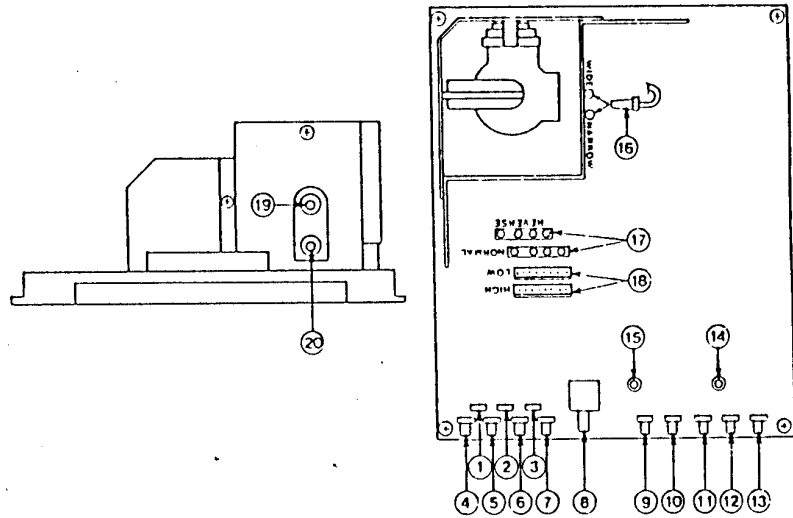

- | | | |
|----------|---------------|--------------------------------------|
| ① R-BIAS | ⑧ H. SIZE | ⑮ H. POSITION |
| ② G-BIAS | ⑨ H. HOLD | ⑯ Screen-Size-Changig Chips |
| ③ B-BIAS | ⑩ H. PHASE | ⑰ Screen-Inversion Connector |
| ④ R-GAIN | ⑪ V. SIZE | ⑱ Horizontal Frequency-Changing Taps |
| ⑤ G-GAIN | ⑫ V. HOLD | ⑲ FOCUS |
| ⑥ B-GAIN | ⑬ V. POSITION | ⑳ SCREEN |
| ⑦ BRIGHT | ⑭ V. LIN | |

★ Caution for Adjusting

- Careless adjustments may result in malfunction such as synchronism, distortion of screen, and/or voltage-rising.
- Never touch the adjustors with white-paint locking.
Also, as higher voltages exist some parts of the monitor unit, extra case must be taken when adjusting.

★ Depending on the setting condition of the machine on location, color aberration may occur. In such, use the degaussing switch or a degaussing device.

Be careful to avoid any magnet or the like nearing the screen, or color aberration will occur.

• Explanation for Adjustors

• R.G.B.-GAIN, BIAS

R.GAIN, BIAS ... for changing the strength of red color

G.GAIN, BIAS ... for changing the strength of green color

B.GAIN, BIAS ... for changing the strength of blue color

• BRIGHT (Brightness Control)

Use this control for adjusting the screen brightness.

Adjust this control depending on the condition of location.

• H.SIZE (Horizontal Width Control)

Use this control for adjusting the horizontal
Picture size.

When adjusting, use a core driver.

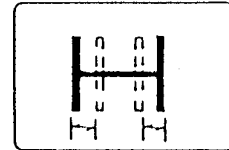

• H.HOLD (Horizontal Hold Control)

Use this control when the picture rolls
horizontally.

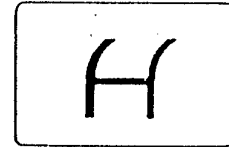

• H.PHASE (Horizontal Phase Control)

Use this control for adjusting the horizontal
timing.

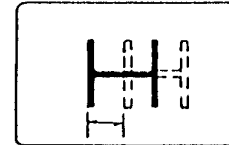

• V.SIZE (Vertical Picture-Size Control)

Use this control for adjusting the vertical
picture size.

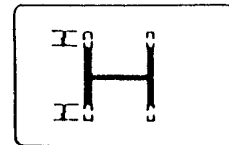

• V.HOLD (Vertical Height Control)

Use this control when the picture rolls
vertically.

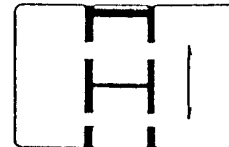

• V.POSITION (Vertical Centering Control)

Use this control to move the picture vertically
onto the desired position.

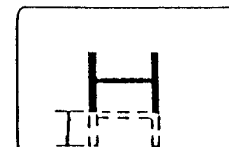

9. Play Instructions

1) Description for Control Part

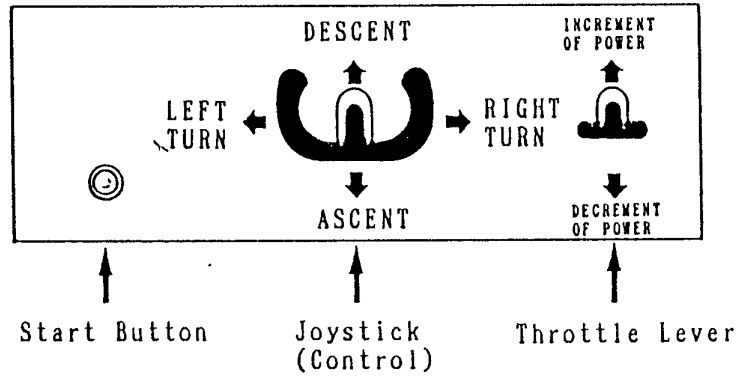

- Start Button ... Use this button to begin a game and to select airports.
- Thottle Lever .. Use this lever to increase or decrease the power when increasing or decreasing the speed.
- Joystick Use this joystick for doing descent, ascent, left turn or right turn as well as for selecting airports.
(Control)

Ascent : Turn downward.

Descent: Turn upward.

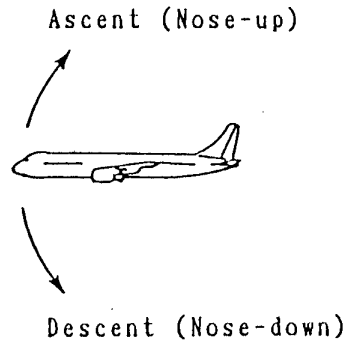

Left Turn : Turn right.

Right Turn: Turn left.

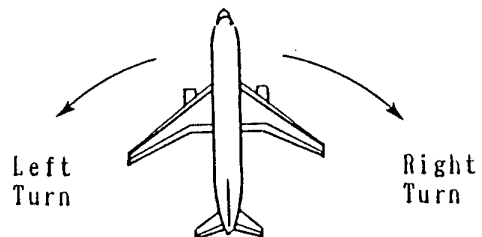

2) Description for Meters on Screen

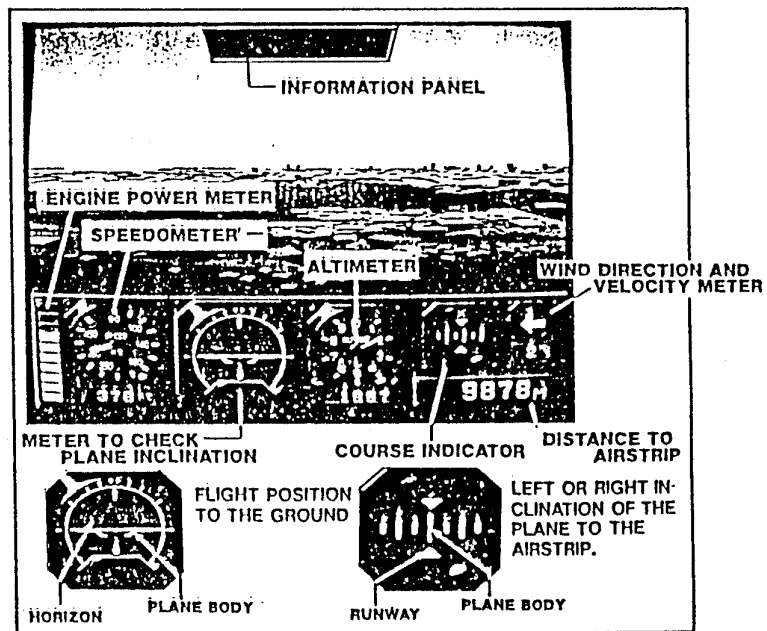

- Information Panel: displays the following notices.

"RIGHT TURN"	→	Turn right !
"LEFT TURN"	→	Turn left !
"UP"	→	Nose up !
"DOWN"	→	Nose down !
"POWER UP"	→	Increase the power ! (only in the taking-off scene)

3) Control Procedure

- ① Insert coins.
(Coins inserted for 10 or more credits are nullified.)
- ② The words "POSITION JOYSTICK AND THROTTLE LEVER POSITIONS SHOWN IN BLUE COLOR" are displayed on the screen .
When the joystick and the throttle lever are positioned into the positions shown in blue color, the words of "PUSH START BUTTON" are displayed on the lower part of the screen.
- ③ By pressing the start button, the game begins.

(Take off Scene)

- A take off should be done according to the indications displayed on the screen.

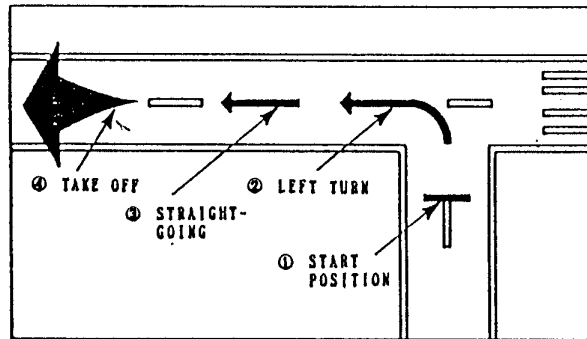

- ① The words of "INCREASE THE POWER SLIGHTLY" are displayed.
Increase the power slightly and move forward.

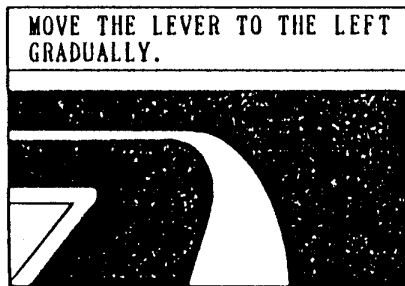

- ② The words of "MOVE THE LEVER TO THE LEFT GRADUALLY" are displayed.
Turn the joystick left and move the plane to the center of the airstrip.
When the plane is moved to the white center line on the airstrip for going straight, the words "READY FOR TAKE-OFF !!" are displayed.

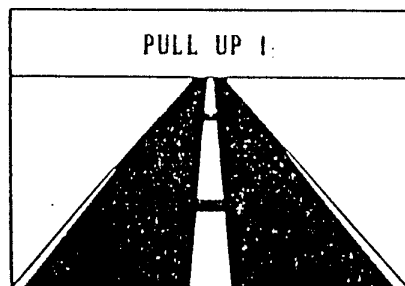

- ③ When the speed reaches 200 kt, the words of "PULL UP!!" are displayed.
Turn the joystick toward you to nose up.

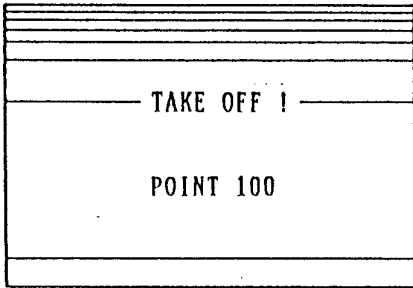

- ④ After taking off, the words of "TAKE-OFF !" are displayed, and points (maximum 100 points) are scored.

• To follow are the failures of take off:

- If the plane goes out from the airstrip before taking off.
- If the plane was unable to take off.
- If the plane did not take off within the given time.

(Selection of Airports)

• After taking off, the screen changes to the landing-selection scene.

- Airports can be selected according to their weather conditions.
- By turning the joystick right or left to move the blue-blashing cursor onto a desired airport for landing, and select it by pressing the start button.

(If no selection has been made within 10 seconds, an airport is selected automatically.)

(Name of Airports)

Tokyo , Fukuoka , Sydney , Rio de Janeiro ,
Osaka , Paris , San Francisco , and Washington D.C.

(Landing Scenes)

• The landing method of this game is the same way as that of the "Midnight Landing".

- ① By using the joystick and the throttle lever, nose down to go to the airstrip on which red calling-on lamps light, and lower the altitude of the plane by adjusting the power.

- ② Just before landing, nose up slightly, and lower the power.
(Approaching speed: 250 kt or less)

- ③ When the plane lands safely on the airstrip, a reverse-jet is produced automatically to stop the plane.
The word of "LANDING" is displayed on the screen.

• Score-decreasing items in landing:

(The scoring system is a low-point method of scoring in which these score-decreasing item points are deducted from the basis of 100 points.)

- If the plane goes up or down in a hurry.
- If the plane fishtails (or zigzags).
- If the approaching speed is too fast.
- If the plane does not move up when approaching into the airstrip.
- If the plane lands on a place which is far away from the correct part of the airstrip.

(Game-over)

- Game ends when the plane failed in landing.
The failures of landing are:

"COURS OUT"	When the plane is far away from the course.
"CRASH"	When the plane comes to the ground.
"OVER RUN"	When the plane overruns the airstrip.

- After clearing all rounds, the ending mode is displayed, then the game ends.

10. TEST MODE

• In the setting that the position 3 of the DIP switch located on the main PCB is turned ON, the test mode can be displayed by turning on the power switch.

① First, the words of "NOW SRAM CHECKING" are displayed, then crosshatching and color bars are displayed, which are to be used for adjusting the screen size and brightness.

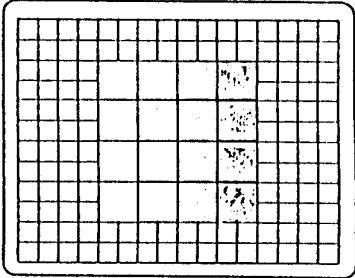

② Next, by pressing the start button, the screen changes to the test mode, on which the function test of the switches as well as the confirmation of the DIP switch settings can be done.

```

TEST MODE
COINA:OFF    COINB:OFF
SERVICE:OFF TILT:OFF
START:OFF    DOOR:OFF
HANDLE U:ON  SLOT U:ON
           D:ON    D:ON
           R:ON
           L:ON
COUNTER 1:0000
          2:0000
          3:0000
          87654321
DIPSWA  HHHHHLHH L:ON
         B  HHHHHHHH H:OFF
SOUND CORD  00
RAM OK      ROM OK
    
```

Note 1: COUNTER 1 → Function Test for Throttle Lever
 " 2 → Function Test for Joystick (Right and Left)
 " 3 → Function Test for Joystick (Up and Down)

Note 2: SOUND CODE
 By turning the joystick right or left, select the sound code.
 Then, the sound output checking can be done by pressing the start button.

* The door switch is not used.

11. Adjustments of Main PC Board

- Open the rejector door, and release the auto latch located on the upper part of the fronto door, and then open the front door.

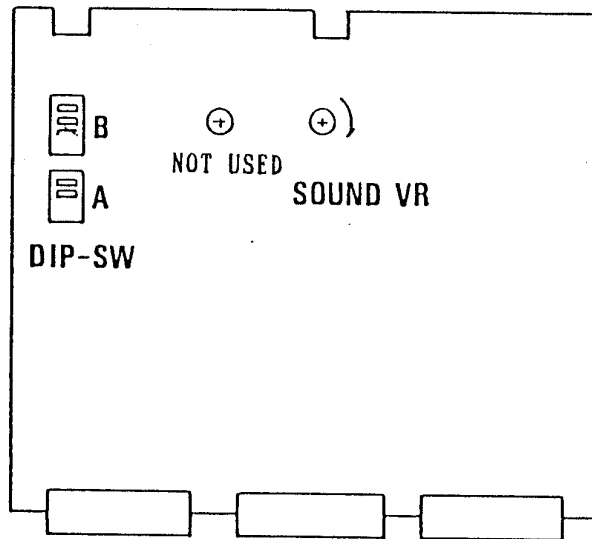

- Sound VR ... The sound volume can be increased by turning to the direction as shown with the arrows. However, these volume controls are not used in a normal condition because the sound volume control is equipped within the rejector door as the central control.

Note: When changing the positions of the DIP switches never fail to turn off the power switch first.

(DIP-SW A)

(*) : FACTORY SETTINGS

SETTING		POSITION		1	2	3	4	5	6	7	8	
TEST MODE	* NORMAL GAME	OFF				OFF						
	TEST MODE				ON							
ATTRACT SOUND	* PRODUCE							OFF				
	NO PRODUCE							ON				
PLAY PRICING (COIN A)	1 COIN 1 PLAY								OFF			
	2 COINS 1 PLAY								ON		OFF	
	3 COINS 1 PLAY								OFF			
	4 COINS 1 PLAY								ON		ON	
PLAY PRICING (COIN B)	1 COIN 2 PLAYS										OFF	
	1 COIN 3 PLAYS										ON	OFF
	1 COIN 4 PLAYS									OFF		
	1 COIN 6 PLAYS									ON	ON	

(D12-SW B)

(*):FACTORY SETTINGS

SETTING	ON	1	2	3	4	5	6	7	8
GAME DIFFICULTY EASY (A)→ DIFFICULT (D)	*	OFF	OFF	OFF					
	RANK A	ON	OFF						
	RANK C	OFF	ON						
	RANK D	ON	ON						

Note: The main PCboard used in this game is for exclusive use for the upright model, not for the mobile cabinet model.

12. How To Remove Control Panel

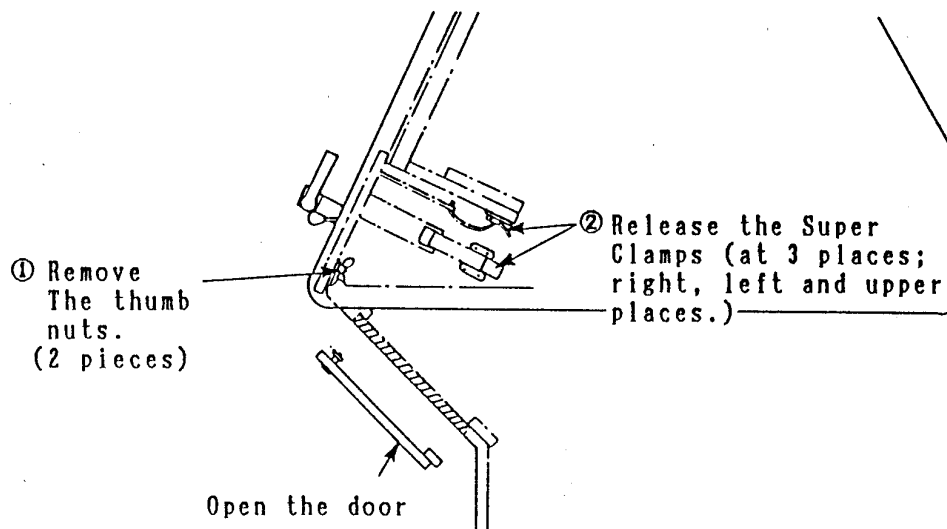

•Procedure:

- ① Open the door located below the control panel, and remove 2 pieces of thumb nuts (M4) on the front side of the panel.
- ② The control panel can be removed after releasing 3 pieces of super clamps located on the both sides and the upper part of the panel and then by unplugging the N- and K-connectors.



PARTS CATALOGUE

U92 00105A	CABINET ASSY (MAIN)
M07 00125A	CABINET ASSY
M05 00149A	REJECTOR & CASH BOX ASSY
M90 01573A	CENTRAL CONTROL ASSY
M90 01234A	FAN ASSY
M90 01512A	FL ASSY
M90 01033A	MAIN SWITCH BOX ASSY
M90 01511A	SWITCH BOX ASSY
M03 15069A	CONTROL PANEL ASSY
M01 00039A	PUSH BUTTON ASSY
M01 00089A	HANDLE CONTROL ASSY
M01 00088A	ACCEL CONTROL ASSY
M90 01513A	PC BOARD SHIELD ASSY

ITEM	PARTS NO.	DESCRIPTION
CABINET ASSY (MAIN) (U92 00105A)		
1	E50 00153A	SERVICE LOCK NO.8800 SINGLE
2	E30 00066A	LOCK GUARD B
3	E30 00008A	LOCK PLATE LONG SIZE
4	E30 05999A	TITLE BRACKET B
5	G95 00369A	TITLE PANEL
6	E30 05998A	TITLE BRACKET A
7	E50 60028A	SUPER CRAMP C-137
8	E30 05994A	STOP BRACKET
9	E50 00093A	AUTO LATCH
10	H30 00041A	MASK
11	D20 00663A	FRONT BOARD
12	H10 04062A	FLENEL LENS (320×390) F900, T=2.0 LN085
13	G15 00222A	FRONT PANEL SHEET
14	H10 00074A	FRONT GLASS
15	G15 00223A	SIDE STICKER A-L
	G15 00224A	SIDE STICKER A-R
16	G15 00225A	SIDE STICKER B-L
	G15 00226A	SIDE STICKER B-R
17	G15 00237A	MARK STICKER 200
18	E30 05996A	EDGE COVER F
19	E30 05997A	EDGE COVER S
20	G15 00058A	HIGH VOLTAGE CAUTION STICKER
21	G95 00371A	DISPLAY BOARD [SPARE PARTS]
CABINET ASSY (M07 00125A)		
22	D30 00162B	CABINET
23	E30 02725A	ROPE HANGER
24	E50 60011A	CASTER 420SR-N D=75
25	E30 06002A	CASTER BRACKET
26	E30 06001A	SUPPORT BRACKET
REJECTOR & CASH BOX ASSY (M05 00149A)		
27	M05 00137A	DOOR & CASH BOX (NO.29311)
28	E50 00113A	LOCK & KEY LY-0069
29	E50 00102A	DOM LOCK
30	E30 03497A	LOCK PLATE
31	E30 05599B	CASH BOX CASE
32	E30 05600B	CASH BOX
33	C17 00035A	COUNTER GX-06F DC5V
	L90 01383B	E HARNESS
	L90 01704A	C HARNESS

● FL & CENTRAL CONTROL ASSY

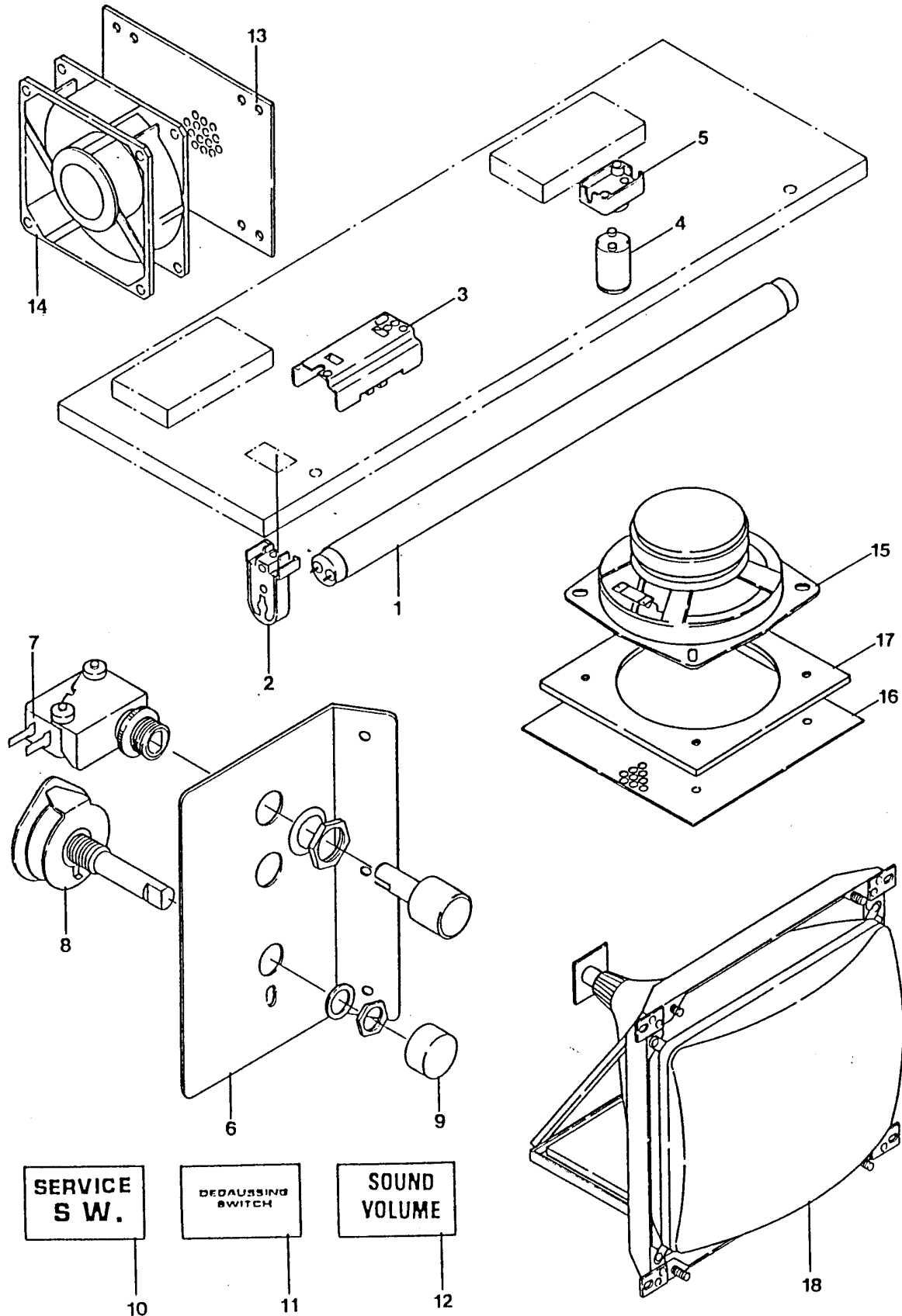

ITEM	PARTS NO.	DESCRIPTION
FL ASSY (M90 01512A)		
1	C15 00004A	FL LAMP 15W
2	C05 50303A	FL SOCKET 1A 250V
3	C10 00304A	CHOKE TRANSFORMER 15W
4	C14 00101A	GLOW LAMP FG-1P
5	C05 50352A	GLOW SOCKET 1A 250V
	L90 01669A	FL HARNESS
CENTRAL CONTROL ASSY (M90 01573A)		
6	E30 05055B	SWITCH BRACKET
7	C02 00033A	PUSH BUTTON SWITCH VAQ-4R
8	C02 00164A	ROTARY SWITCH T505-134
9	E90 00416A	KNOB
10	G10 00186A	SERVICE SWITCH STICKER
11	G10 10010A	DEGAUSSING SWITCH STICKER
12	G10 00219A	SOUND VOLUME STICKER
	L90 01365A	D HARNESS
FAN ASSY (M90 01234A)		
13	E30 01004A	PUNCHING PLATE B
14	C12 00058A	FAN WEJ-55B4
CABINET ASSY (MAIN) (U92 00105A)		
15	A60 00102A	SPEAKER 8 OHM 15W 12CM
16	E30 01336A	PUNCHING METAL
17	D20 00046A	SPEAKER BOARD
18	M08 00094A	VIDEO ASSY 20" MS8-20HT

● CABINET ASSY

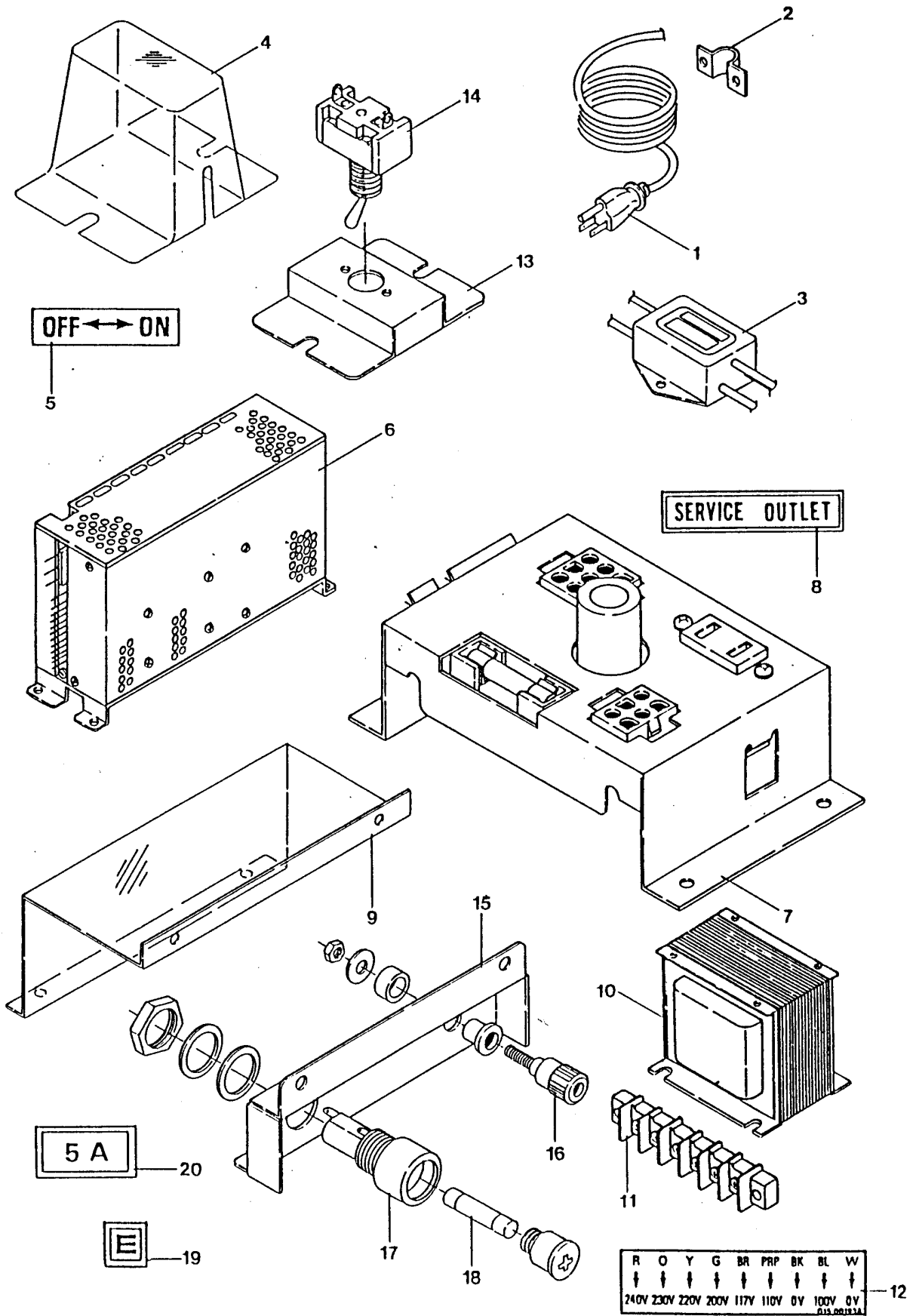

ITEM	PARTS NO.	DESCRIPTION
	CABINET ASSY (MAIN) (U92 00105A)	
1	C07 00208A	AC CORD 3C
2	F90 00048A	CORD STOP
3	C18 00008A	NOISE FILTER ZMB2206-02
4	F90 00636A	MAIN SWITCH COVER
5	G10 00304A	ON-OFF STICKER
6	M41 00023B	SWITCHING REGULATOR
7	M41 00027A	CONNECTOR BOX ASSY
8	G10 00002A	SERVICE OUT STICKER
9	F90 00909A	SWITCH COVER
10	C10 00358A	TRANSFORMER
11	C06 00330A	D-TYPE TERMINAL 6P ML-2015C
12	G15 00193A	VOLTAGE STICKER
	L90 01713A	S HARNESS
	L90 01714A	Z HARNESS
	L10 00160A	MAIN HARNESS
	MAIN SWITCH BOX ASSY (M90 01033A)	
13	E30 01861A	MAIN SWITCH BOX
14	C02 00020A	TOGGLE SWITCH ET125A-12
	SWITCH BOX ASSY (M90 01511A)	
15	E30 05056A	FUSE BRACKET
16	C06 01002A	EARTH TERMINAL T-375 BK
17	C05 50144A	FUSE HOLDER S-N 2056
18	C16 00037A	FUSE 5A
19	G10 00113A	CONNECTOR STICKER E
20	G10 00093A	FUSE STICKER 5A

● CONTROL PANEL ASSY

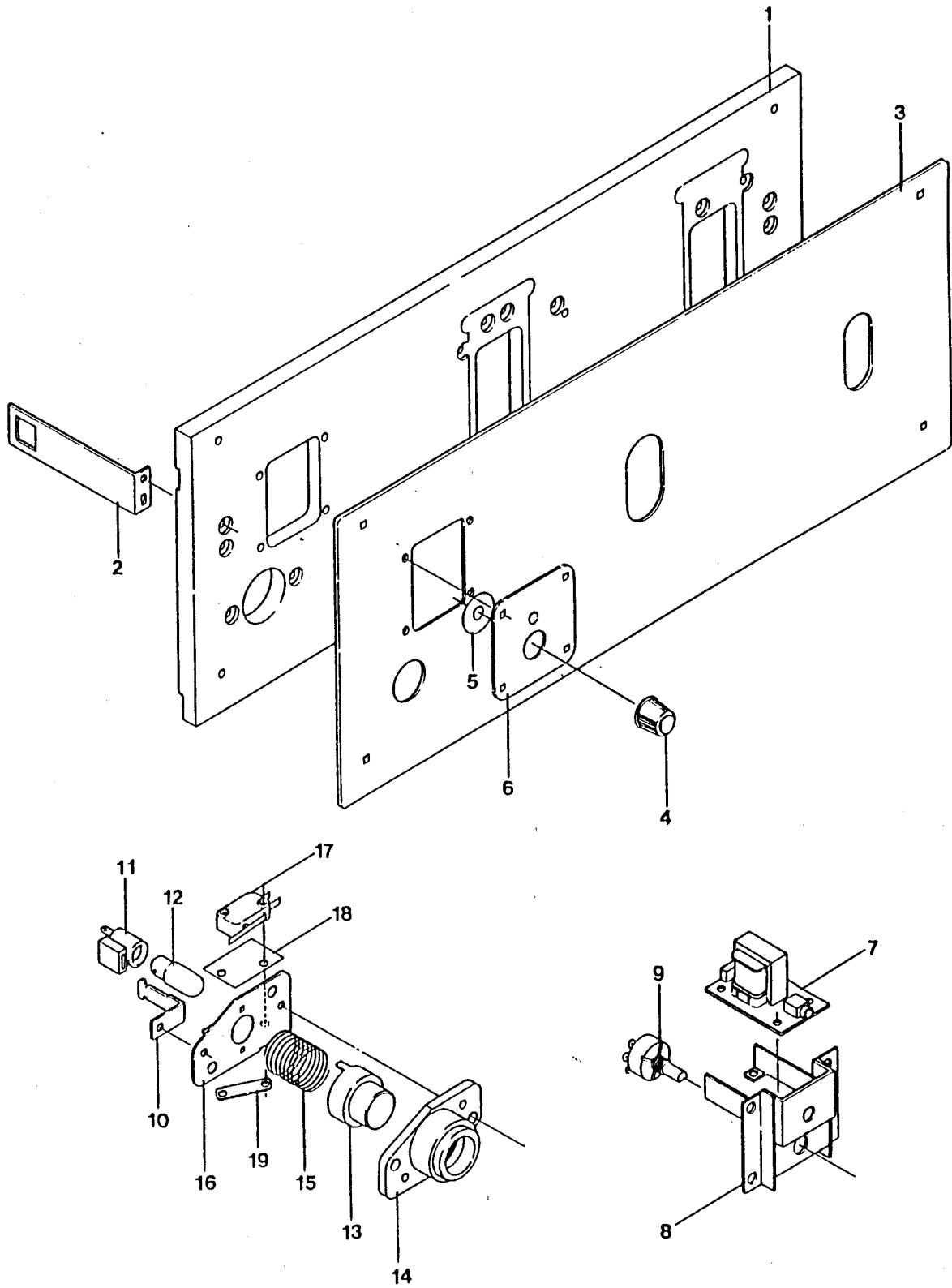

● HANDLE CONTROL ASSY

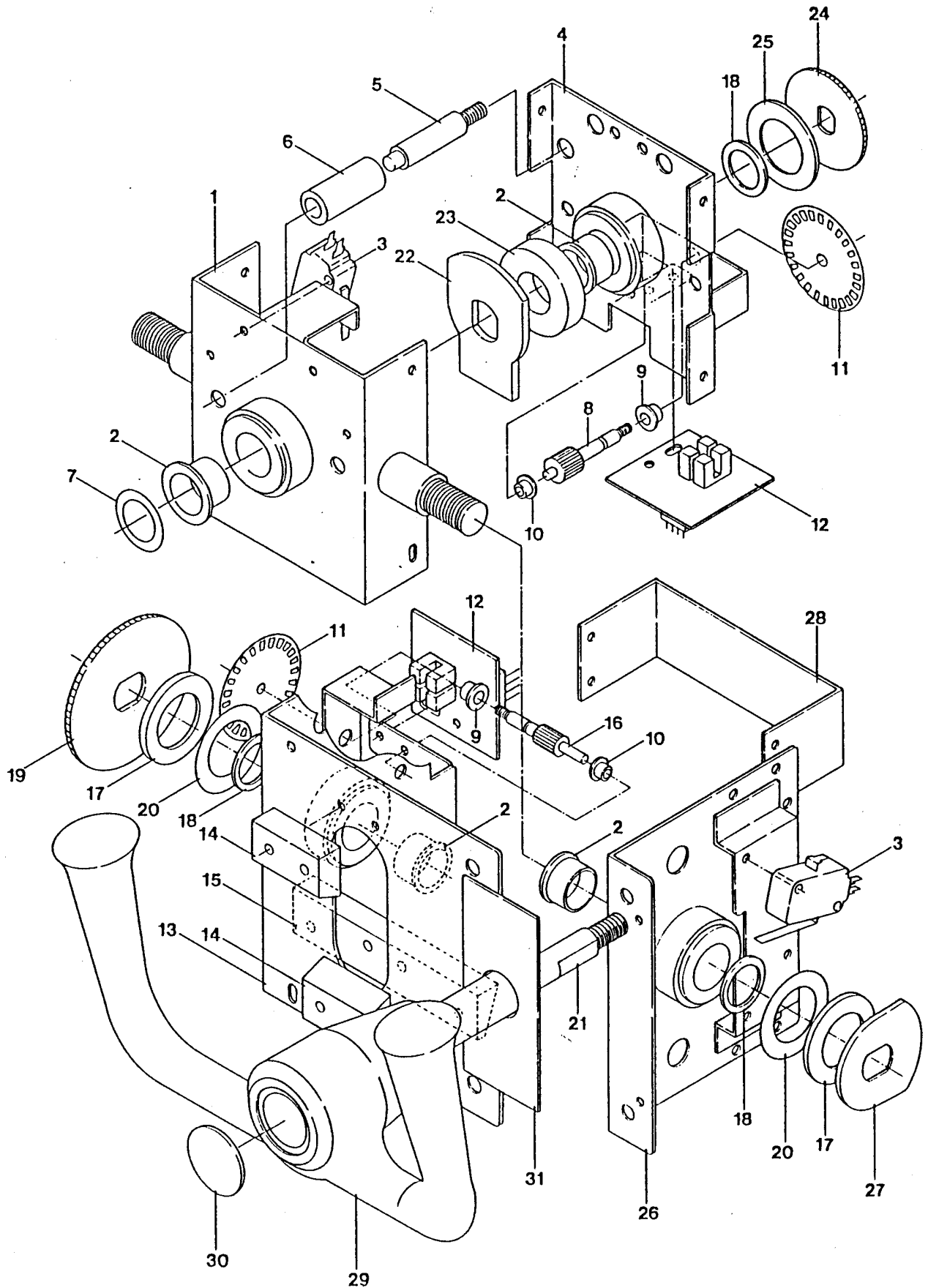

●ACCEL CONTROL ASSY

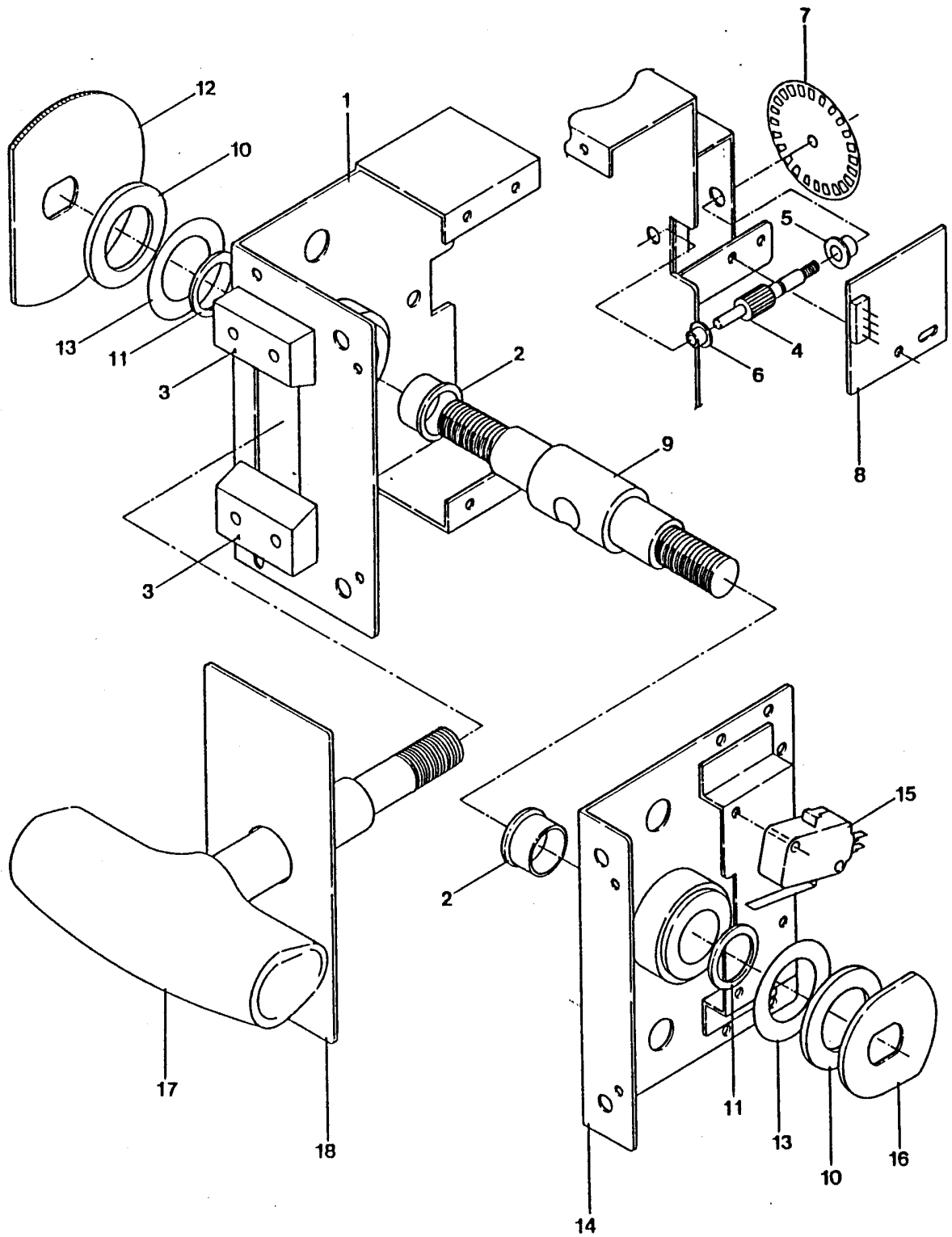

● PC BOARD SHIELD ASSY

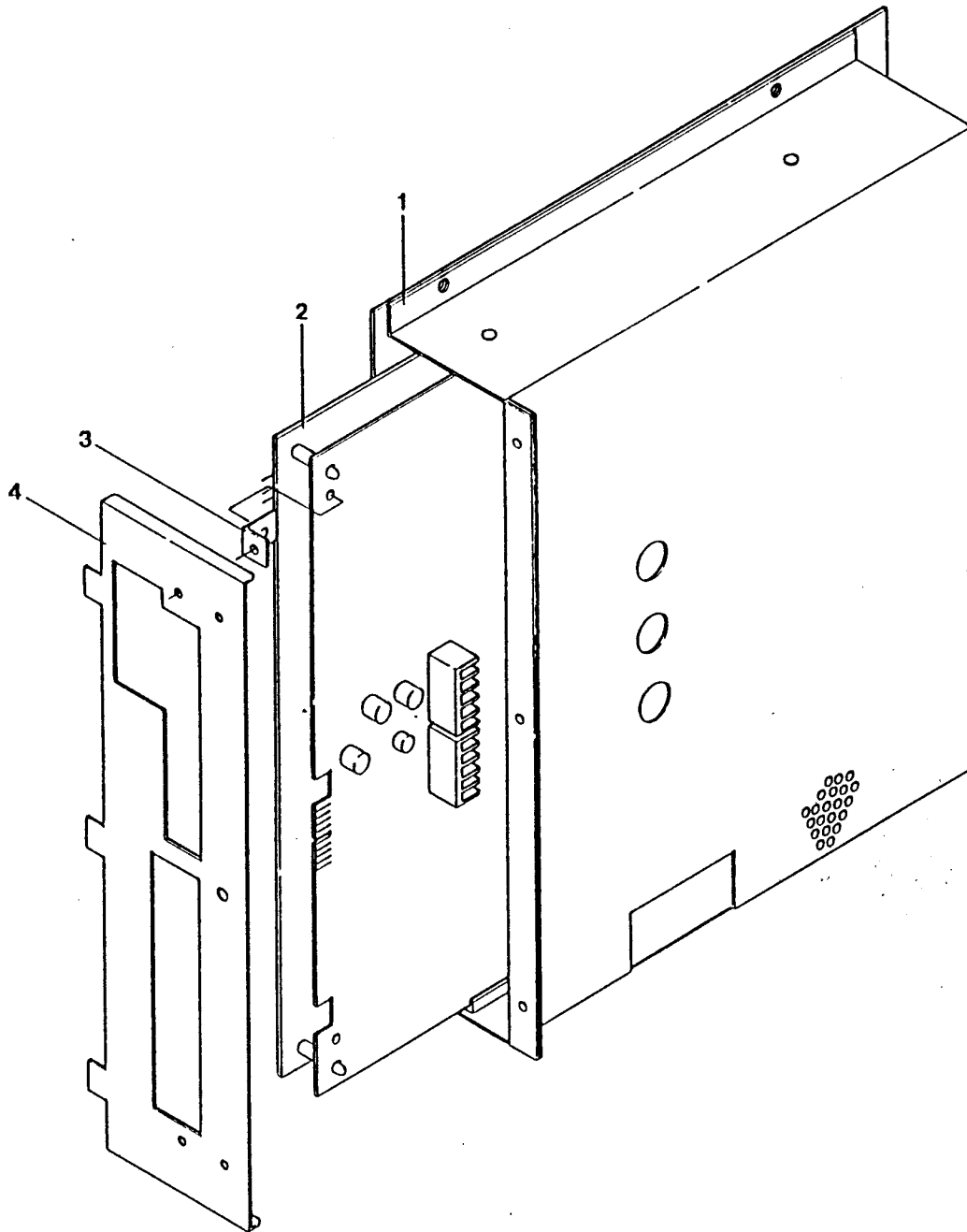

ITEM	PARTS NO.	DESCRIPTION
	PC BOARD SHIELD ASSY (M90 01513A)	
1	H90 00232A	SHIELD CASE
2	M43 00114A or M43 00115A	MAIN PC BOARD ASSY
3	E30 05995A	EARTH JOINT
4	E30 06000A	SHIELD DOOR

REVISING		DATE	APPROVED
1	DESCRIPTION		

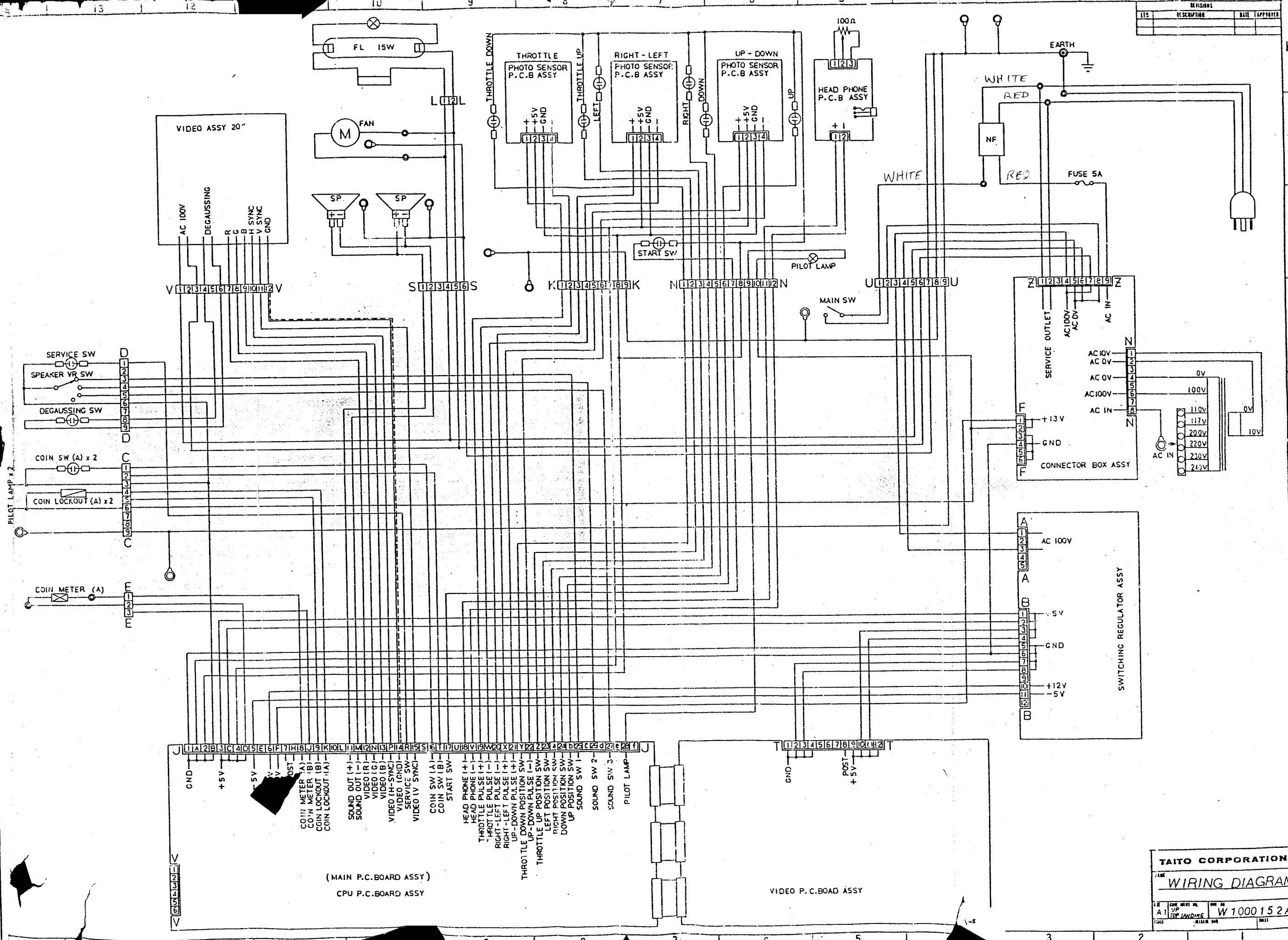

(MAIN P.C. BOARD ASSY)
CPU P.C. BOARD ASSY

VIDEO P.C. BOARD ASSY

TAITO CORPORATION
WIRING DIAGRAM
W 100015 2A