

CAR POLO

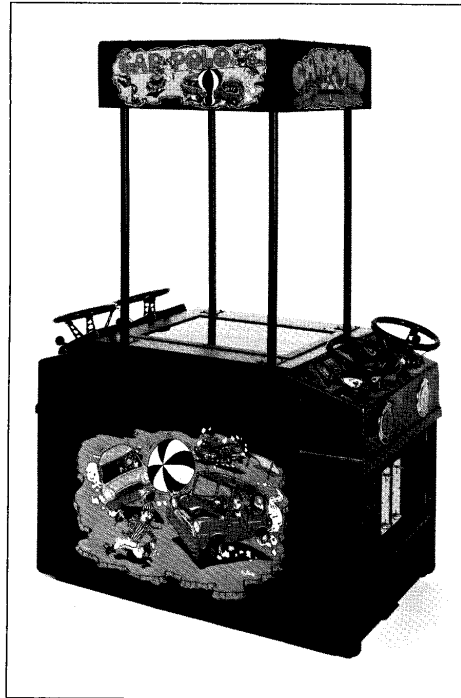

**EXIDY
SERVICE
MANUAL**

**PART TWO
TECHNICAL DATA**

TABLE OF CONTENTS

1. Removal of steering control module	1
2. Removal of PCB	1
3. Removal of monitor	2
4. Theory of operation	3

FIGURES

1. System Block Diagram	7
2. Memory Map	8
3. Schematics	9

REMOVAL OF A PLASTIC STEERING CONTROL MODULE

PROCEDURE:

1. Disconnect game from AC power outlet.
2. Open coin door on control module side.
3. Unbolt the four (4) hex through bolts from the underside of the module.
4. Disconnect the harness from the module.
5. Lift the module out and up from the game cabinet.

TO REMOVE P.C.B.

1. Disconnect power to game.
2. Open door to blue car side of cabinet.
3. Remove cash box from blue car side.
4. Remove 2 hex 7/16 bolts located behind cleat at the back of the cash box compartment.
5. Slide foot box out of game. (NOTE: Foot pedal harness is still connected. Caution should be taken to protect this harness.)
6. Facing the P.C.B. mounted on the floor of the cabinet, remove the connectors from the board.
7. Pivot the two metal tabs that secure the P.C.B. in the slotted mount up and out away from the board.
8. Remove the P.C.B. from its mount by sliding it towards you.

REMOVAL OF THE MONITOR
(See Figure 14)

NOTE: Removal of the color monitor from the game cabinet is accomplished by sliding the monitor out one end of the cabinet on the wooden side rails. To gain clearance for the monitor, the top glass bezel assembly and the blue team plastic steering control module must be removed from the cabinet.

PROCEDURE:

1. Disconnect game from AC power outlet.
2. Open the coin doors at both ends of the cabinet.
3. Remove the glass view plate parts: view plate frame (C), view plate gasket (D), glass view plate (E) and bezel (F), by unbolting eight (8) through bolts from the top of the cabinet.
4. Remove the plastic steering control module (G) from the blue team end of the cabinet by unbolting the four hex bolts located through the 2 x 2 end blocks under the control box. The harness to the module is disconnected and the module is lifted out and up from the cabinet.
5. Unbolt the metal monitor bracket and rack from the cabinet side rails by removing the two hex through bolts at either end of the cabinet rails.
6. Loosen the main harness from the side wall of the monitor on the blue team end of the cabinet.
7. Two persons can now slide the monitor out of the cabinet through the blue end side of the cabinet.
8. The monitor may be placed on its bottom or back for service. CAUTION: The CRT neck is in an exposed position and is protected by the monitor rack only when the monitor is placed on a flat clean surface.

THEORY OF OPERATION (Figure 1)

CAR POLO is a microprocessor game capable of simultaneous control of four cars, a ball and a special character (referee) on a color television screen. In addition, there is a capability of writing up to 256 alphanumeric characters on the screen.

The microprocessor used in CAR POLO is a MOS TECHNOLOGY 6502, 8 bit microprocessor. For more information on this processor, refer to MOS TECHNOLOGY PUBLICATION # 6500-10A, MCS 6500 Micro-computer Family Hardware Manual. It is an inherent characteristic of this processor that it treats all peripherals attached to it as if they were memory. Therefore, all memory in this system has been mapped. (See Figure 2, Memory Map). The only random access memory assigned for use by the game program is the base page (addresses 0000 - 00FF). The game program uses this memory for storage of temporary data during the course of a game (example, car horizontal position). In addition, 256 bytes of random access memory (addresses 0100 - 01FF) are assigned to the processor for use as a stack.

The CAR POLO program is just slightly less than four kilobytes long and exists in prom from addresses F000 to FFC5. The top eight addresses are used to store the interrupt and reset vectors.

The processor writes alphanumerics on the screen by writing them into a random access memory at locations 3000 - 30FF. The video display logic then reads the data out of that ram, converts it to a video wave-train and displays it on the screen. The format for an alphanumeric byte is:

MSB	7	6	5	4	3	2	1	0	LSB
	ASCII Character						Color Select.		Bit Function

The coding for the color is as follows:

BIT	1	0
WHITE	0	0
GREEN	0	1
BLUE	1	0
RED	1	1

Car, ball and special character horizontal and vertical positions are controlled by writing them into the ram at addresses 4000 - 400F. The functions assigned to each ram location are:

4000	Player	1	Horizontal Position
4001	Player	1	Vertical Position
4002	Player	2	Horizontal Position
4003	Player	2	Vertical Position
4004	Player	3	Horizontal Position
4005	Player	3	Vertical Position
4006	Player	4	Horizontal Position
4007	Player	4	Vertical Position
4008	Ball		Horizontal Position
4009	Ball		Vertical Position
400A	Special Character		Horizontal Position
400B	Special Character		Vertical Position
400C	Players 1 & 2		Rotation
400D	Players 3 & 4		Rotation
400E	Ball Control		Bits
400F	Special Character		Bits

Once, at the beginning of each frame, the same logic halts the processor, extracts the data from the position portion of the ram and uses that data to preload the position counters. It then loads the rotation data into the rotation ram to be used in selection of the image to be displayed. The processor is then allowed to run again.

To display an image the horizontal and vertical positions and the rotation angle are multiplexed and combined to select the desired line in the image prom. The data from the prom is then loaded parallel into the shift register and shifted out serially at the instant when the image is to appear on the screen.

All of the images, including alphanumerics, are prioritized and converted into RGB color signals in the video generation circuitry, where, along with combined cync, they are sent to the color television to be displayed.

The processor detects collisions on the screen by the use of interrupts. The outputs of the shift registers are anded together in the interrupt detection and conditioning circuitry. If this circuitry detects two or more objects in the same place on the screen at the same time, (example: a car and a car collision) it sends out a pulse which interrupts the processor. The processor, at this time, knows that something has occurred, but doesn't know what. By reading memory location C000, it receives an eight bit word telling what type of interrupt it was. It then reads the interrupt data from the following locations:

A000 Ball and Border Data

A000	Ball and Goal Data Ball and Score Zone Data
A001	Interrupting Car Horizontal Position
A002	Interrupting Car Vertical Position
A003	Which Car Interrupted
A004	Car and Border Data
A005	Car and Ball Data
A006	Car and Goal Data
A007	Game Time Switch Setting

After servicing the interrupt, the processor clears the interrupts by writing into locations B000 to B007.

B000	Clear Ball and Goal Interrupt
B001	Clear Time Interrupt
B002	Not Used
B003	Clear Car and Car Interrupt
B004	Clear Car and Border Interrupt
B005	Clear Car and Ball Interrupt
B006	Clear Car and Goal Interrupt

Coin drops also generate an interrupt. Which player generated the coin drop is determined by reading location C000.

The processor interfaces with the outside world with two peripheral interface adaptors. These PIA's are wired to respond to addresses 5400, 5402, 5800 and 5802. The data which is interfaced through these devices is:

PIA # 1, A Side (5400)

Bit 0	Coin Counter Output
Bit 1	Player 4 Crash (to Audio)

Bit 2 Player 3 Crash (to Audio)
Bit 3 Clear Steering Wheel Logic
Bit 4 Player 2 Crash (to Audio)
Bit 5 Score Pulse (to Audio)
Bit 6 Player 1 Crash (to Audio)
Bit 7 Ball Hit Pulse (to Audio)

PIA # 1, B Side (5402)

Bit 0 Strobe Speed Bits Out (to Audio)
Bit 1 Speed Bit 0 Out (to Audio)
Bit 2 Speed Bit 1 Out (to Audio)
Bit 3 Speed Bit 2 Out (to Audio)
Bit 4 Speed Bit 0 In (From Foot Pedals)
Bit 5 Speed Bit 1 In (From Foot Pedals)
Bit 6 Select Foot Pedal Assembly Output 0
Bit 7 Select Foot Pedal Assembly Output 1

PIA # 2, A Side (5800)

Bit 0 Player 4 Steering Input (Left or Right)
Bit 1 Player 3 Steering Input (Left or Right)
Bit 2 Player 2 Steering Input (Left or Right)
Bit 3 Player 1 Steering Input (Left or Right)
Bit 4 Player 4 Forward/Reverse Input
Bit 5 Player 3 Forward/Reverse Input
Bit 6 Player 2 Forward/Reverse Input
Bit 7 Player 1 Forward/Reverse Input

PIA # 1, B Side (5802)

Bit 0 Player 4 Active Output (to Audio)
Bit 1 Player 3 Active Output (to Audio)
Bit 2 Player 2 Active Output (to Audio)
Bit 3 Player 1 Active Output (to Audio)
Bit 4 Player 4 Steering Input (Wheel Moving)
Bit 5 Player 3 Steering Input (Wheel Moving)
Bit 6 Player 2 Steering Input (Wheel Moving)
Bit 7 Player 1 Steering Input (Wheel Moving)

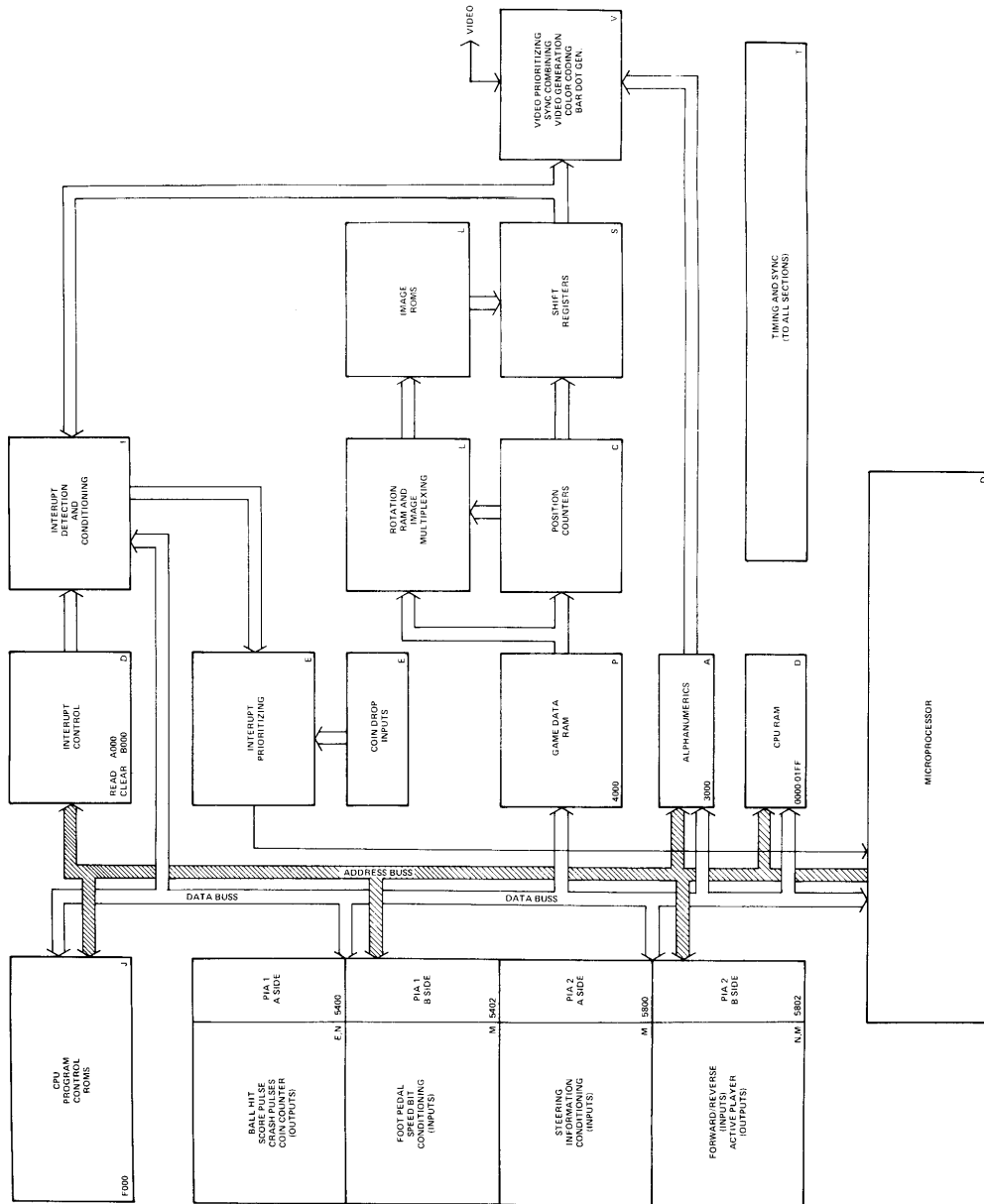

FIGURE 13. LOGIC BOARD BLOCK DIAGRAM

FFFF	FFF8 - FFFF Interrupt Vectors
F000	F000 - FFC8 Game Program
EFFF	
E000	Not Used
DFFF	
D000	Not Used
CFFF	
C000	C000 Read Interrupt Vector
BFFF	
B000	B000 - B00F = Clear Interrupt Data
AFFF	
A000	A000 - A00F = Read Interrupt Data
9FFF	
9000	Not Used
8FFF	
8000	Not Used
7FFF	
7000	Not Used
6FFF	
6000	Not Used
5FFF	
5000	5800 = PIA2A 5802 = PIA2B
4FFF	5400 = PIA1A 5402 = PIA1B
4000	4000 - 400F Game Data
3FFF	
3000	3000 - 30FF Alphanumerics
2FFF	
2000	Not Used
1FFF	
1000	Not Used
0FFF	
0000	0100 - 01FF = Stack 0000 - 00FF = Base Page

CAR POLO

COPYRIGHT 1977 ALL RIGHTS RESERVED BY EXIDY INC.

SCHEMATIC

DIAGRAMS

EXIDY INC.

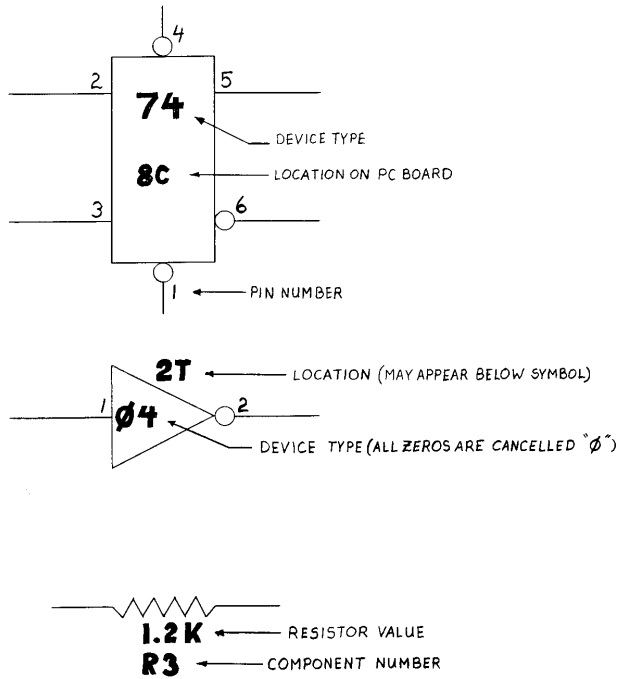

NOTES:

- ALL DEVICES EXCEPT FOR; 533, 8T95, 8T28, 2111, 6331, 652Ø, 21Ø1, LM 38Ø, RØ3 2513, 334Ø, AND NE566 ARE 7400 SERIES TTL, THE 74 PREFIX DOES NOT APPEAR IN THE SCHEMATIC DRAWINGS.
- CLOCK SIGNALS:

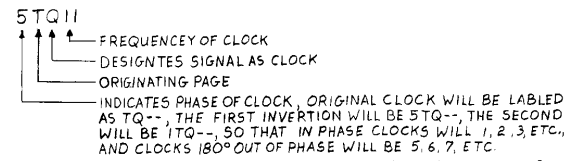
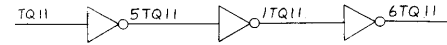

- GROUND SYMBOLS, THERE ARE FOUR SYMBOLS USED IN CAR POLO;

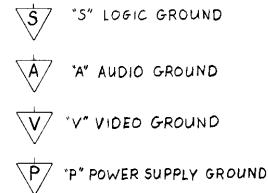

- LETTERS THAT APPEAR BETWEEN BRACKETS, < >, DENOTE TO WHICH PAGES THAT SIGNAL GOES. HENCE A SIGNAL THAT APPEARS THUS;

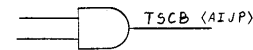

WOULD GO TO THE A, I, J, AND P PAGES. SIGNALS THAT ORIGINATE AND TERMINATE ON THE SAME PAGE.

TYDA

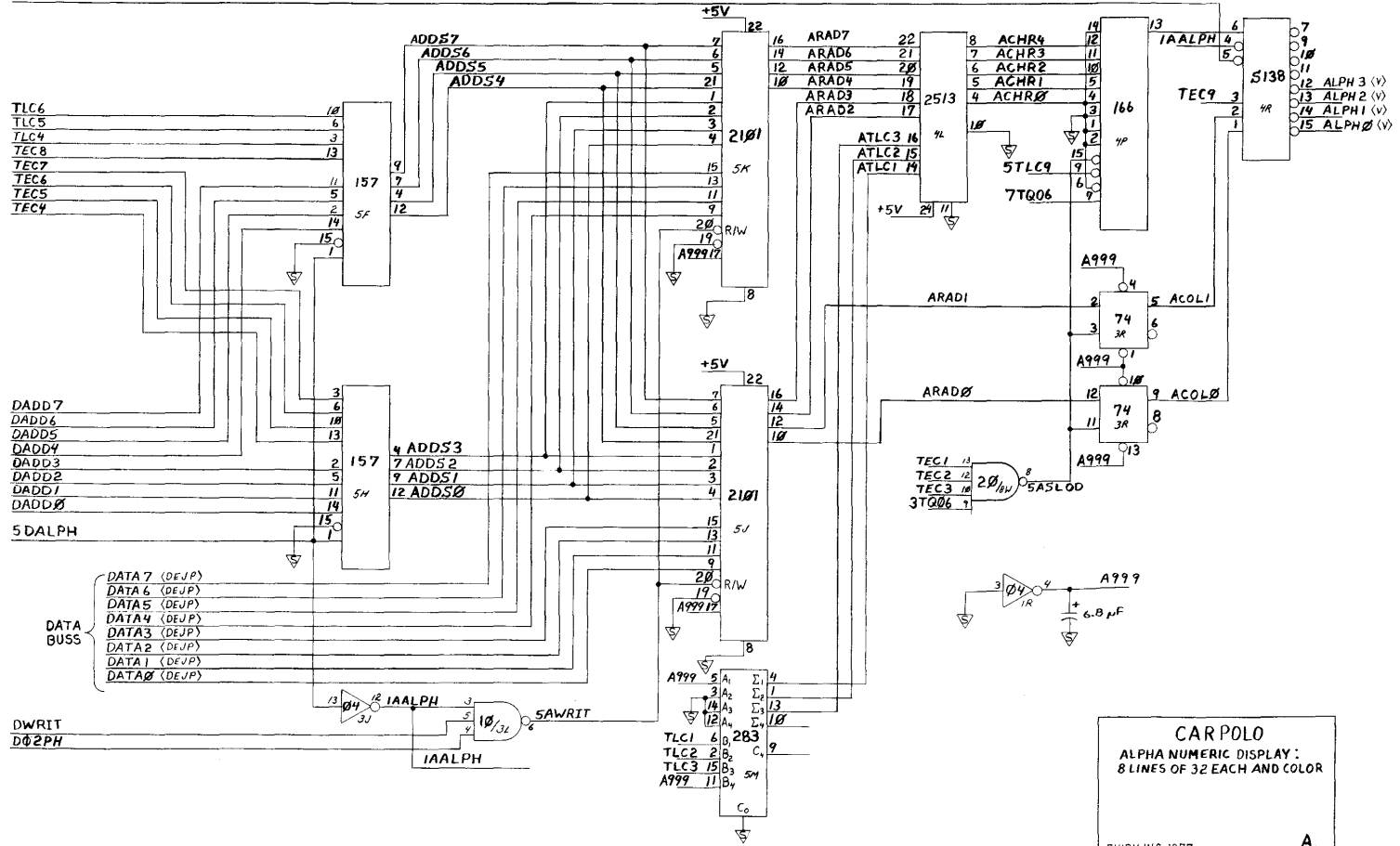

CARPOLO
 ALPHA NUMERIC DISPLAY:
 8 LINES OF 32 EACH AND COLOR
 EXIDY INC 1977
 A.

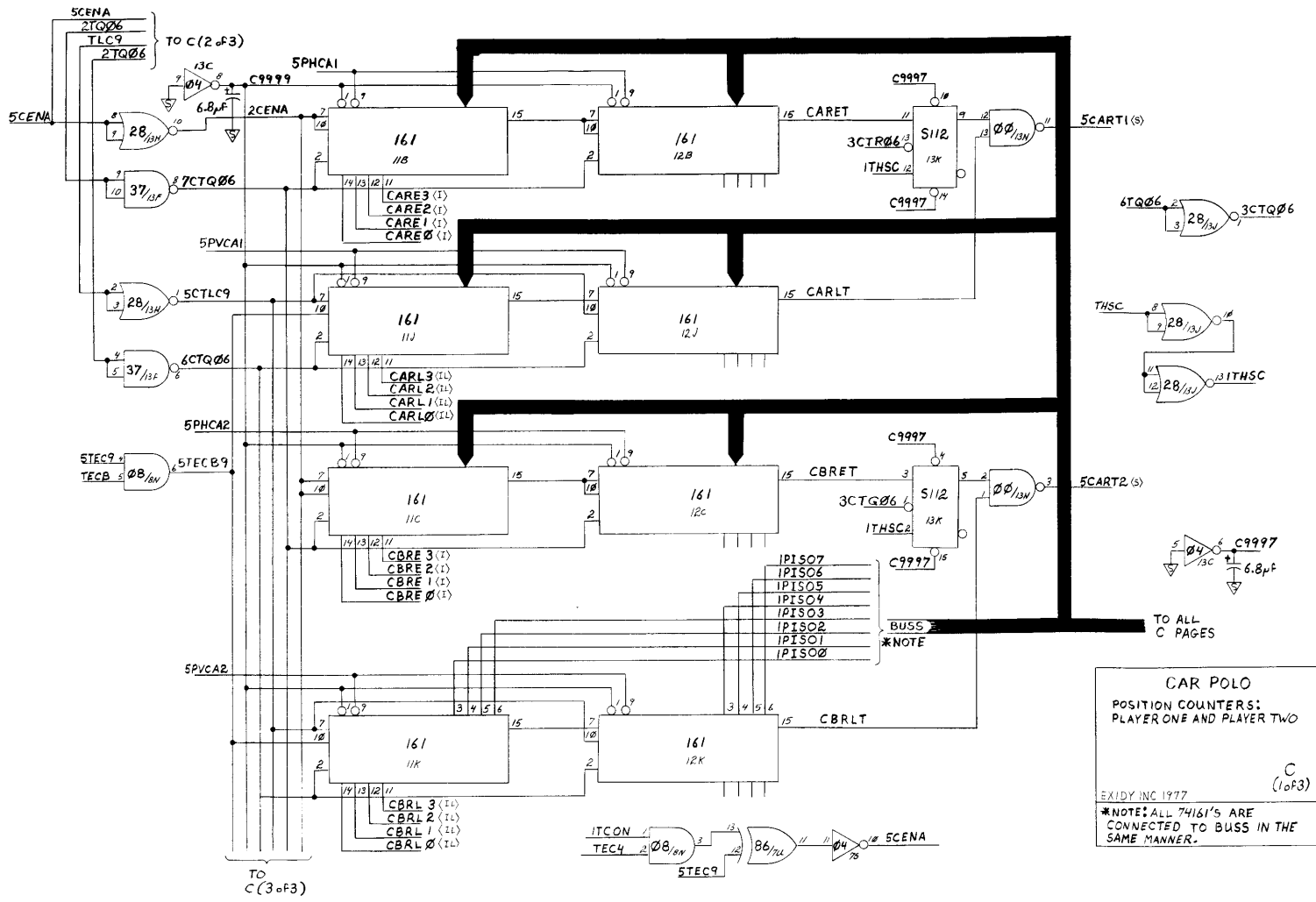

CAR POLO
POSITION COUNTERS:
PLAYER ONE AND PLAYER TWO

C
(1 of 3)

EXIDY INC 1977

*NOTE: ALL 74161'S ARE CONNECTED TO BUSS IN THE SAME MANNER.

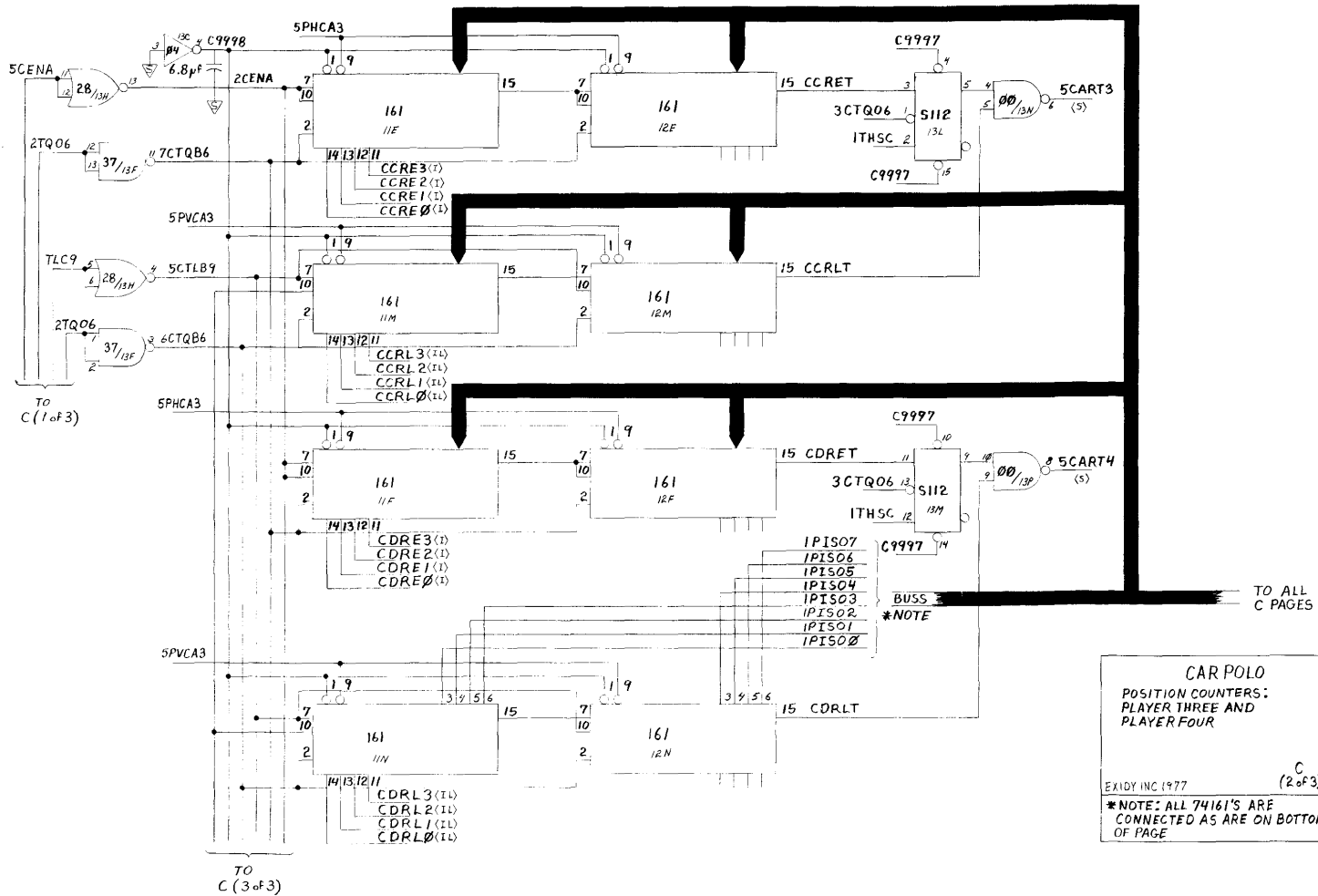

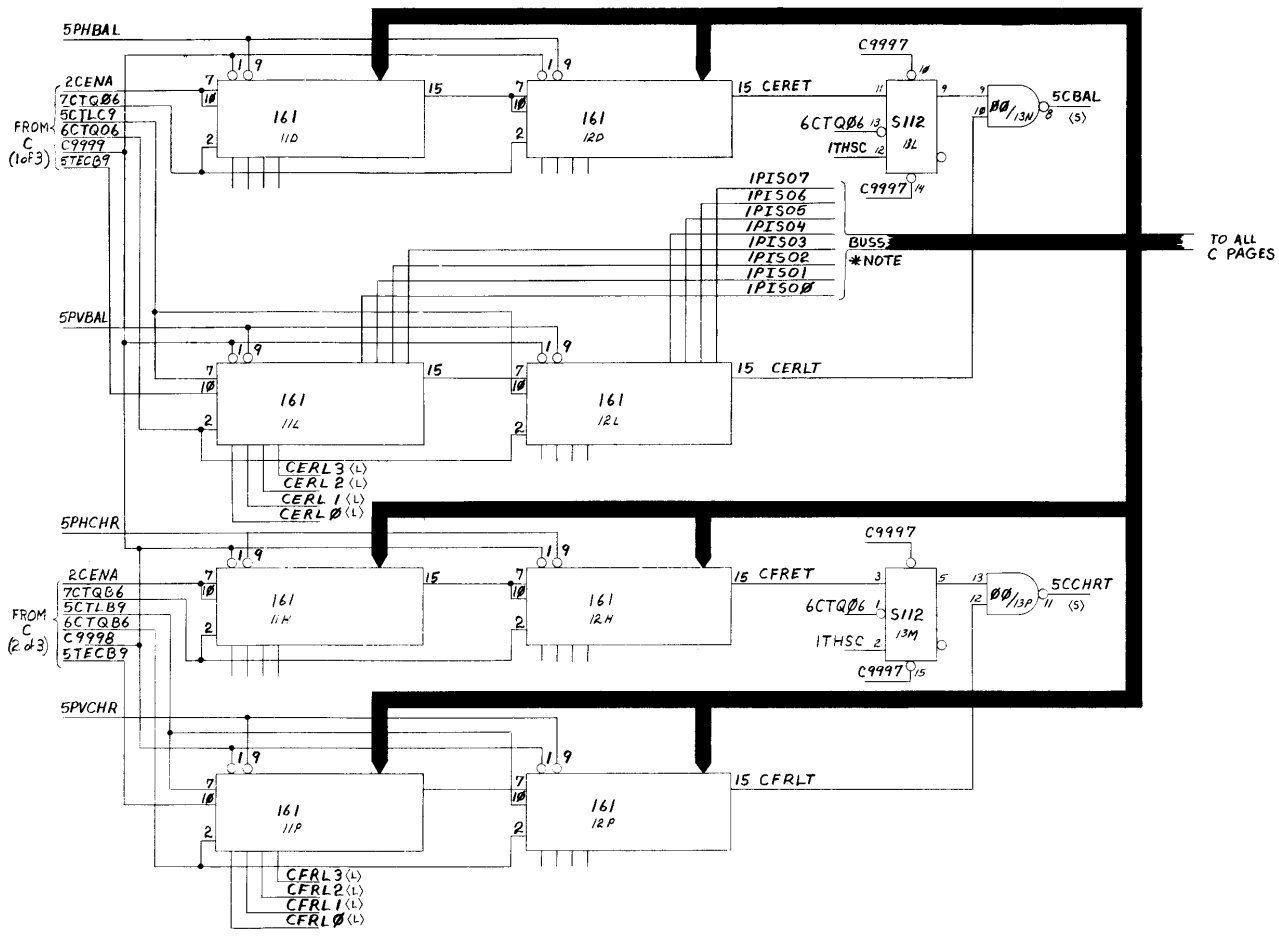

TO ALL C PAGES

CAR POLO
 POSITION COUNTERS:
 BALL AND CHARACTER

EXIDY INC 1977
 C
 (3 of 3)

*NOTE: ALL 74161'S ARE
 CONNECTED TO BUSS
 THE SAME.

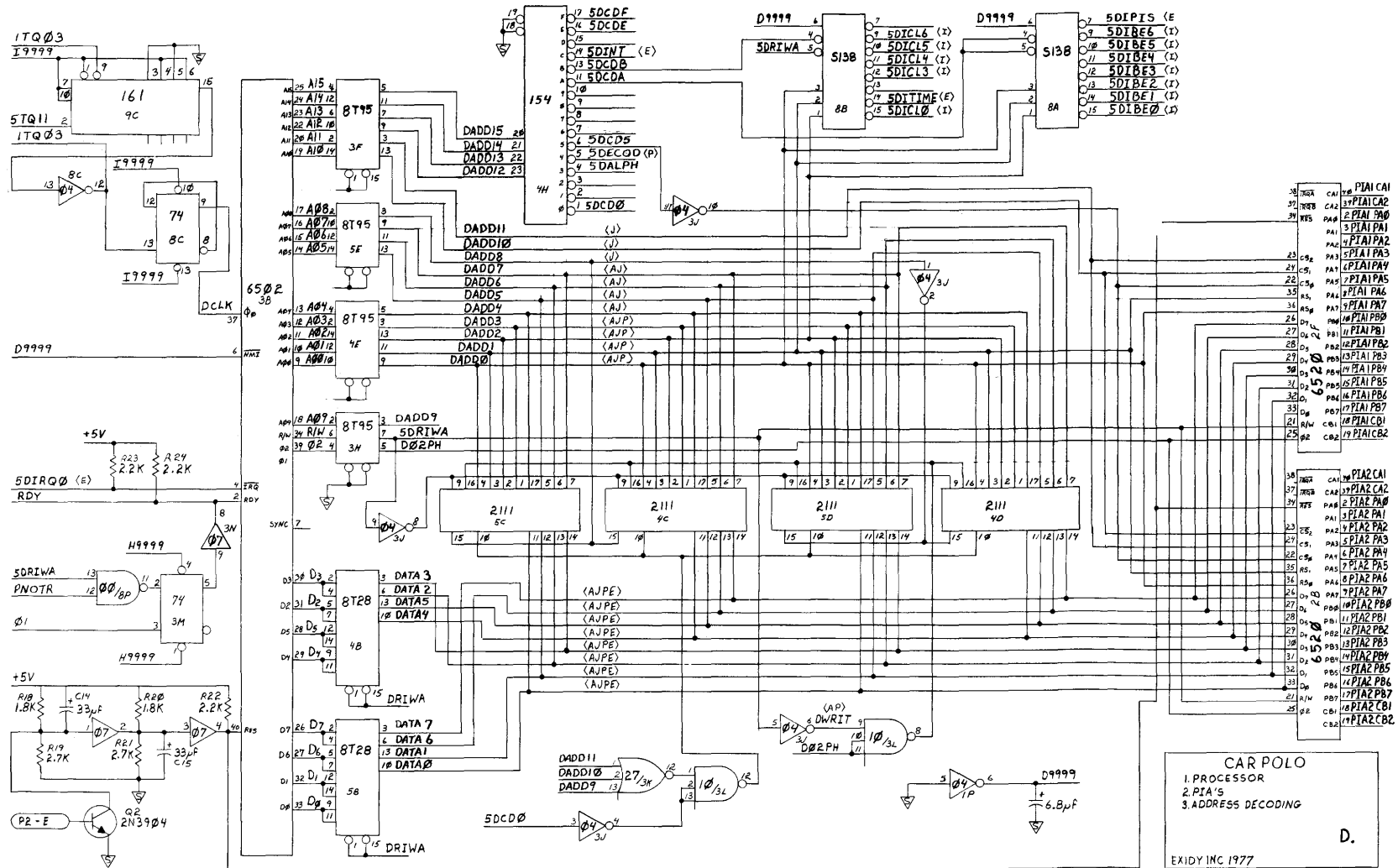

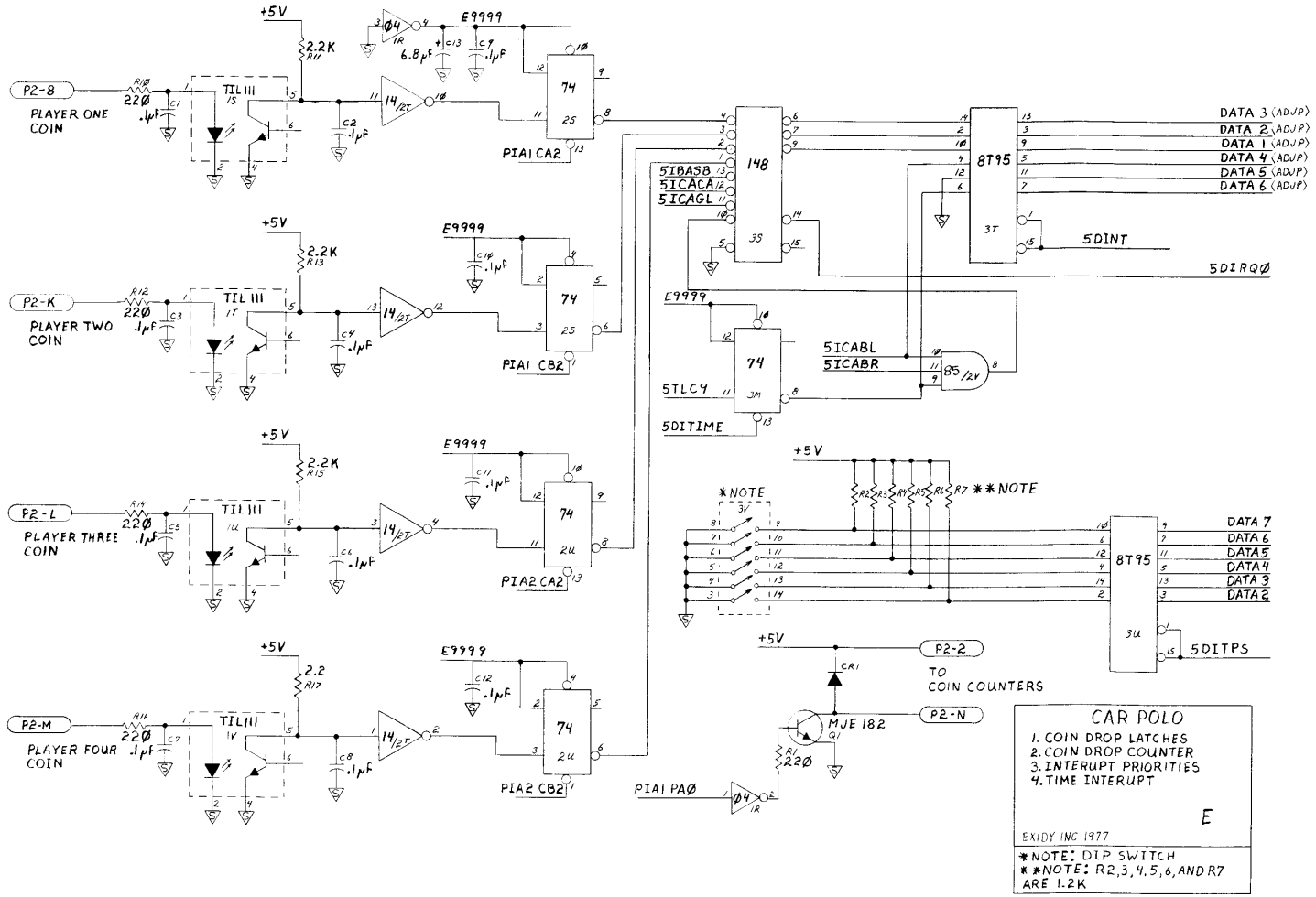

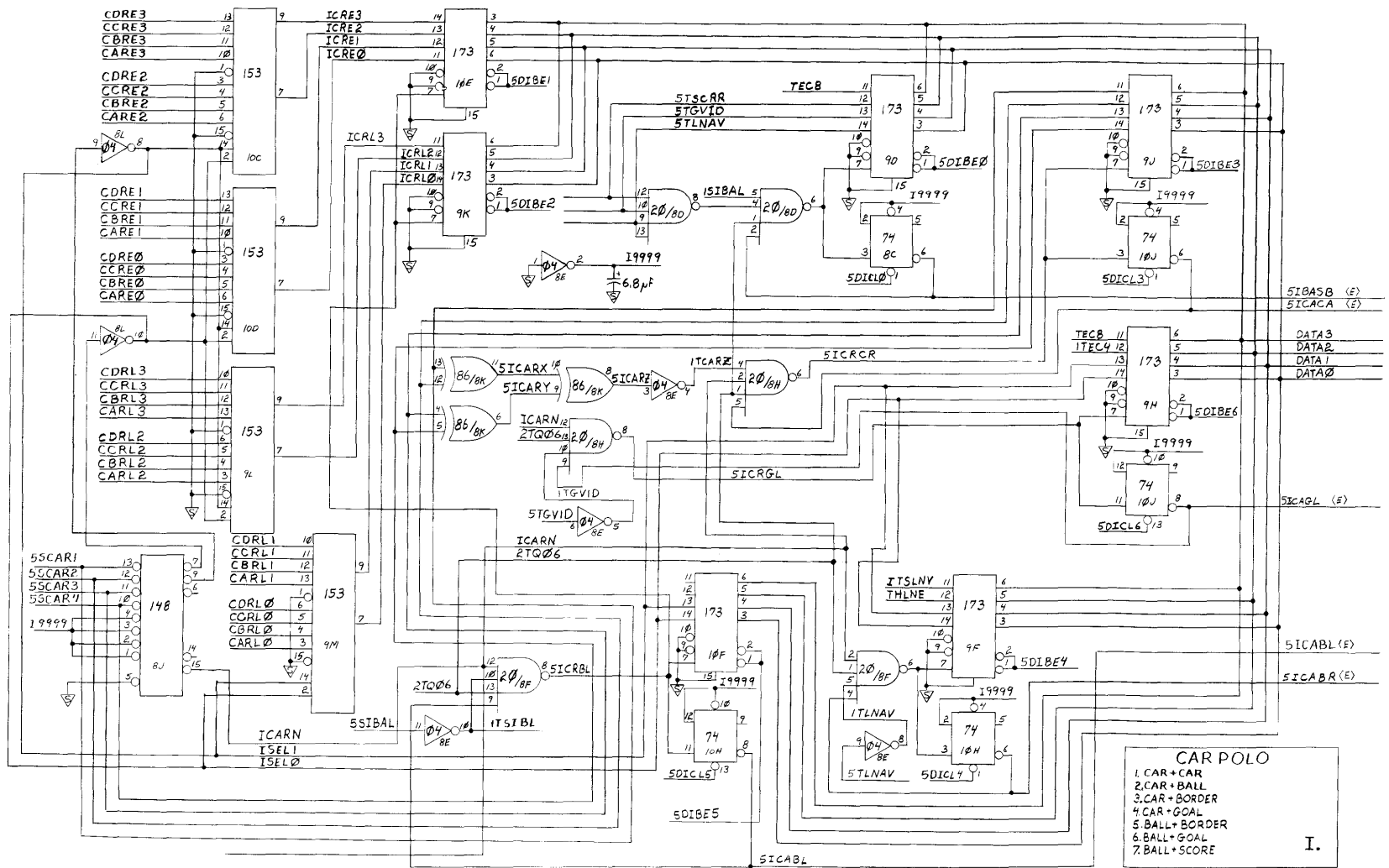

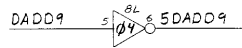
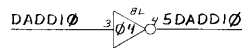
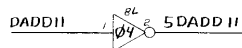
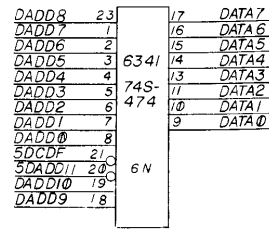
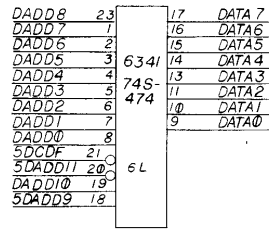
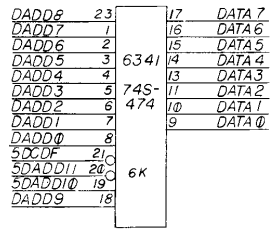
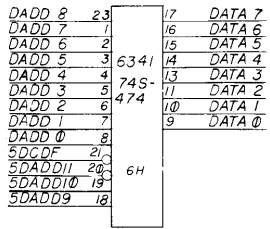
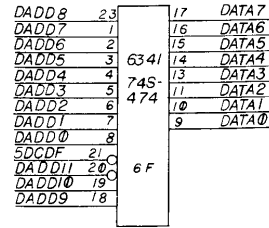
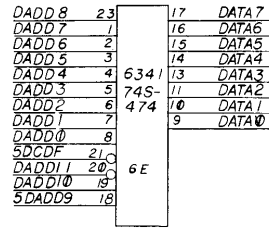
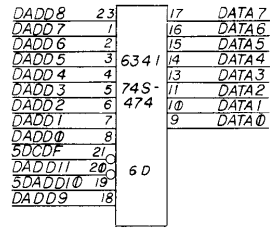
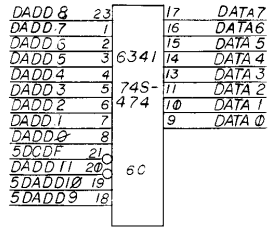

CAR POLO
MEMORY
EXIDY INC 1977

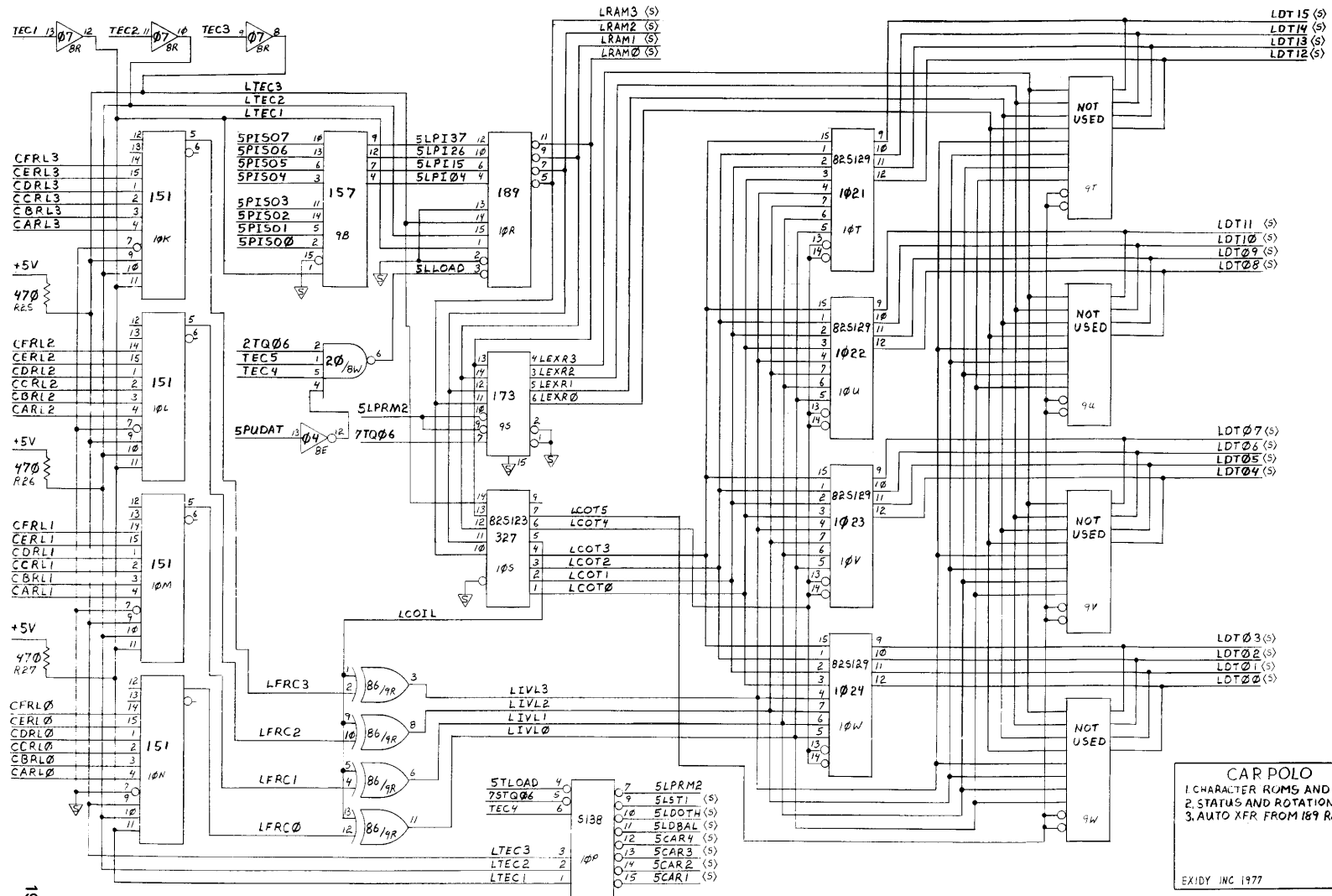

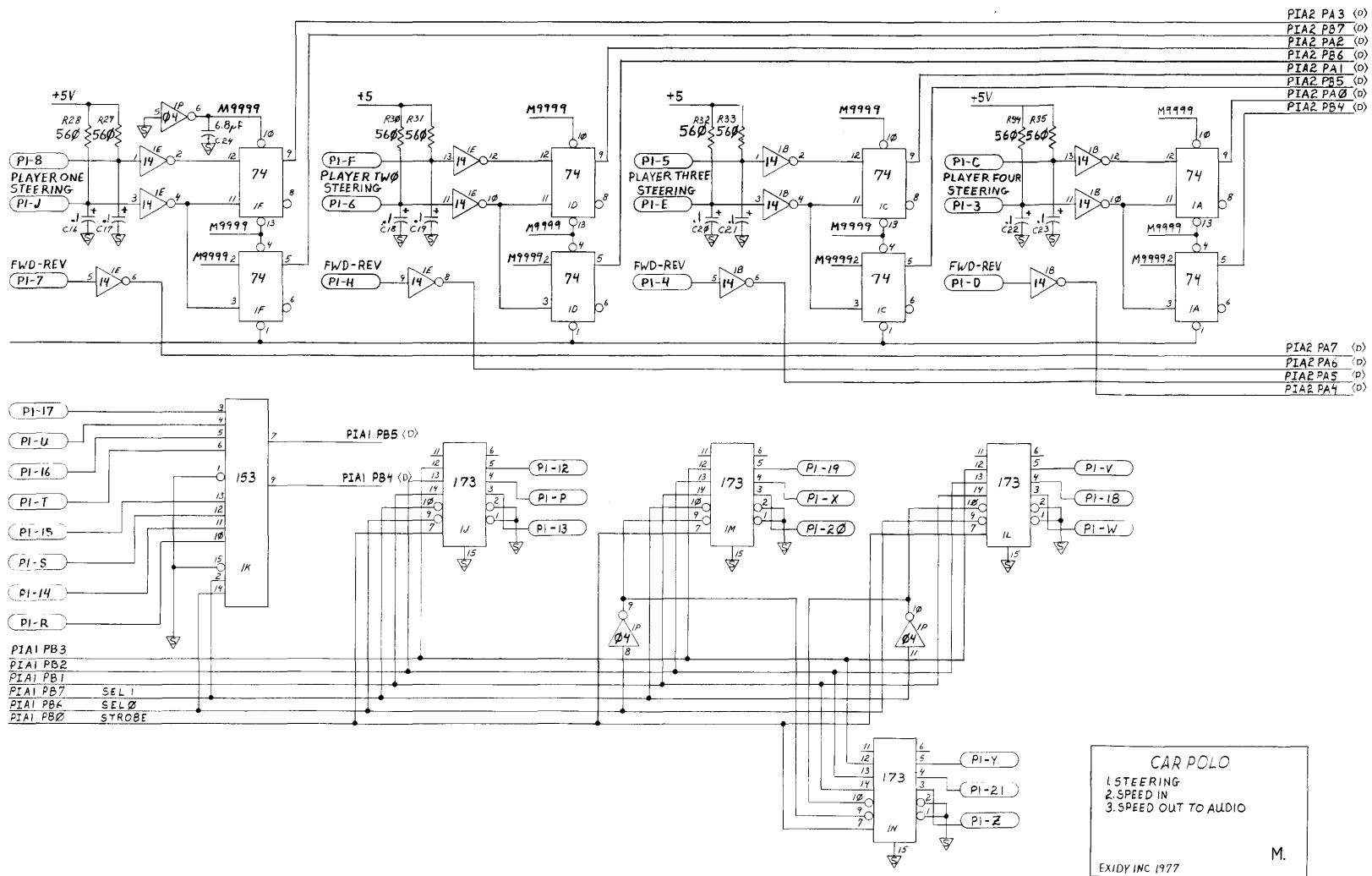

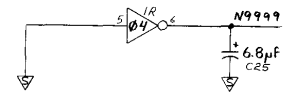
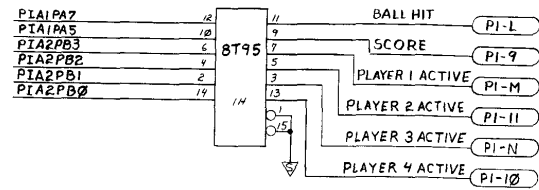
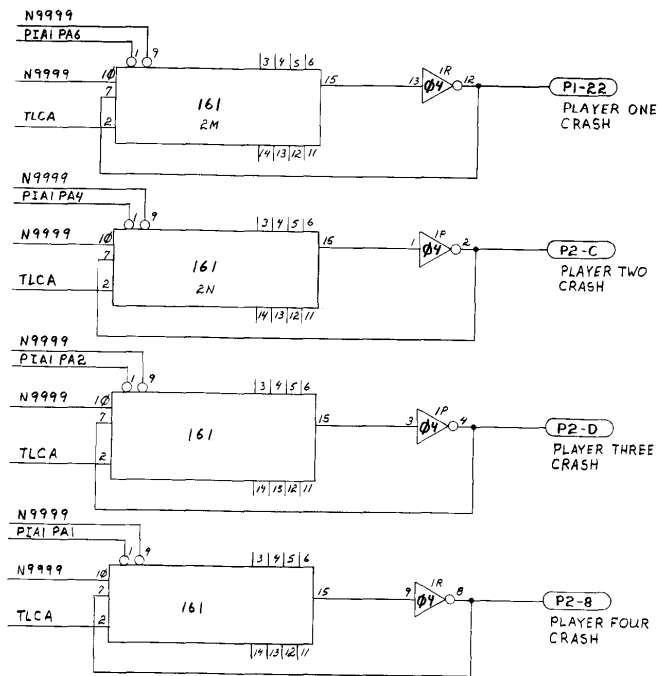

CAR POLO
 1. CRASH PULSE EXTENDERS
 2. AUDIO SIGNAL BUFFERS
 N
 EXIDY INC 1977

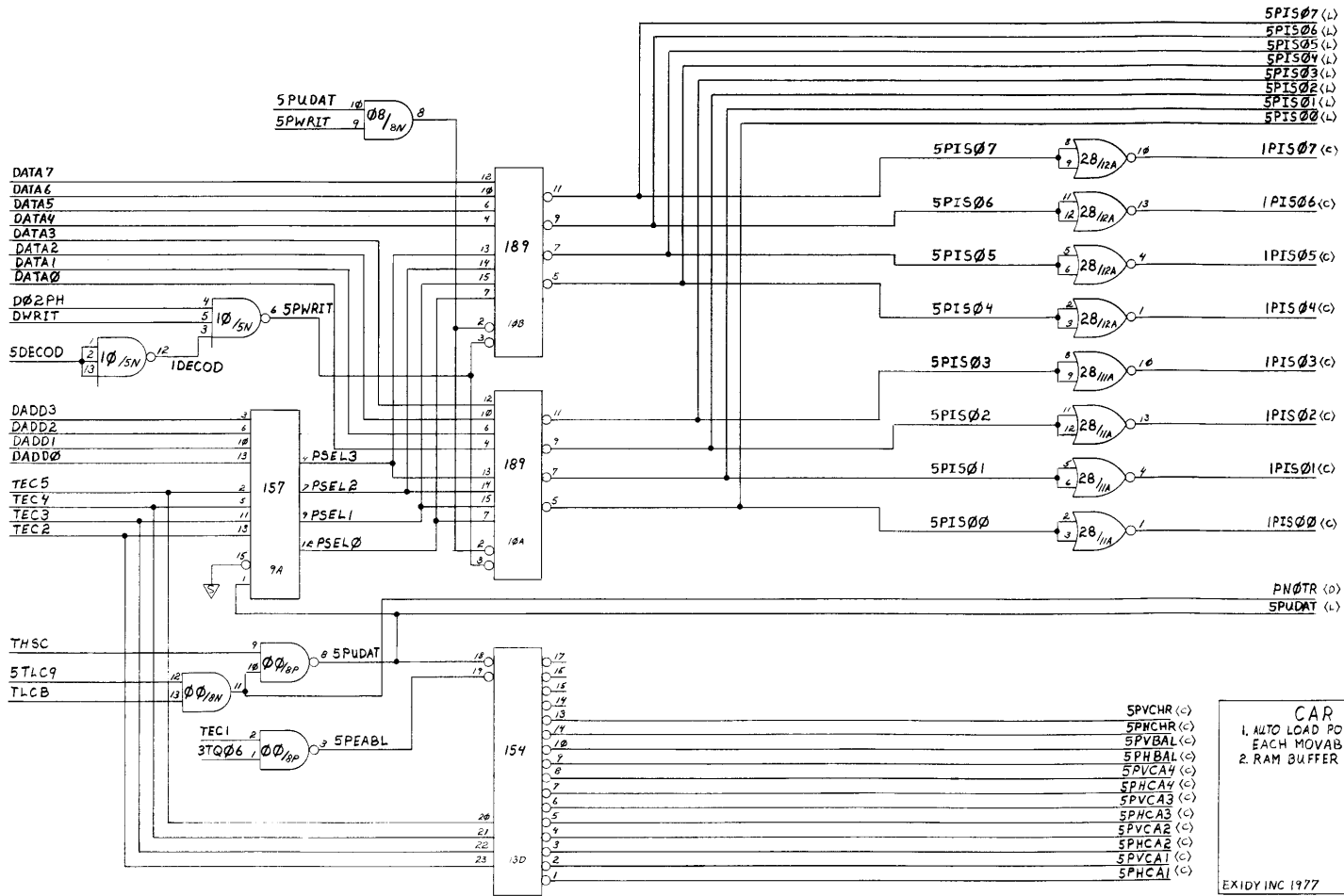

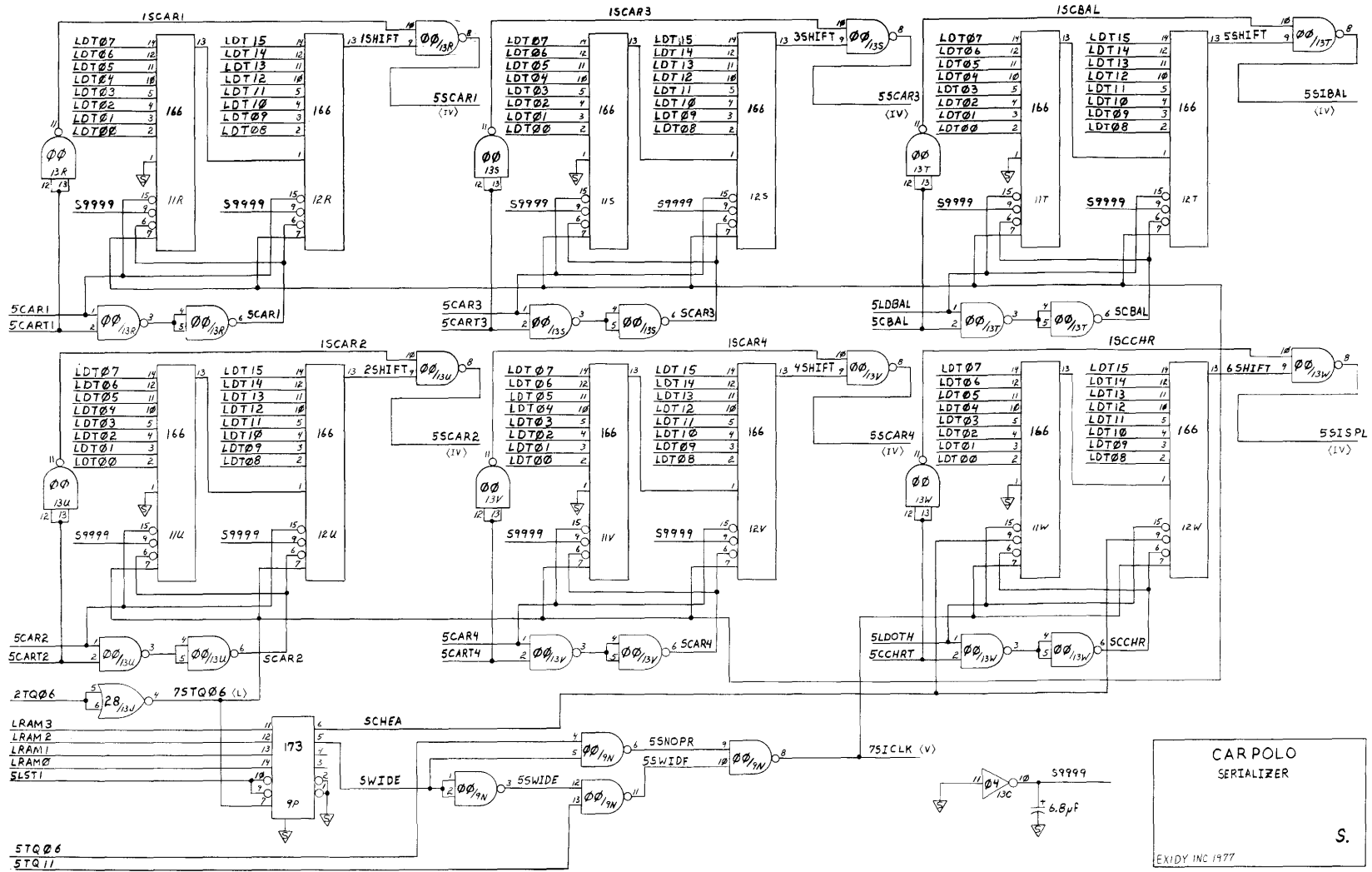

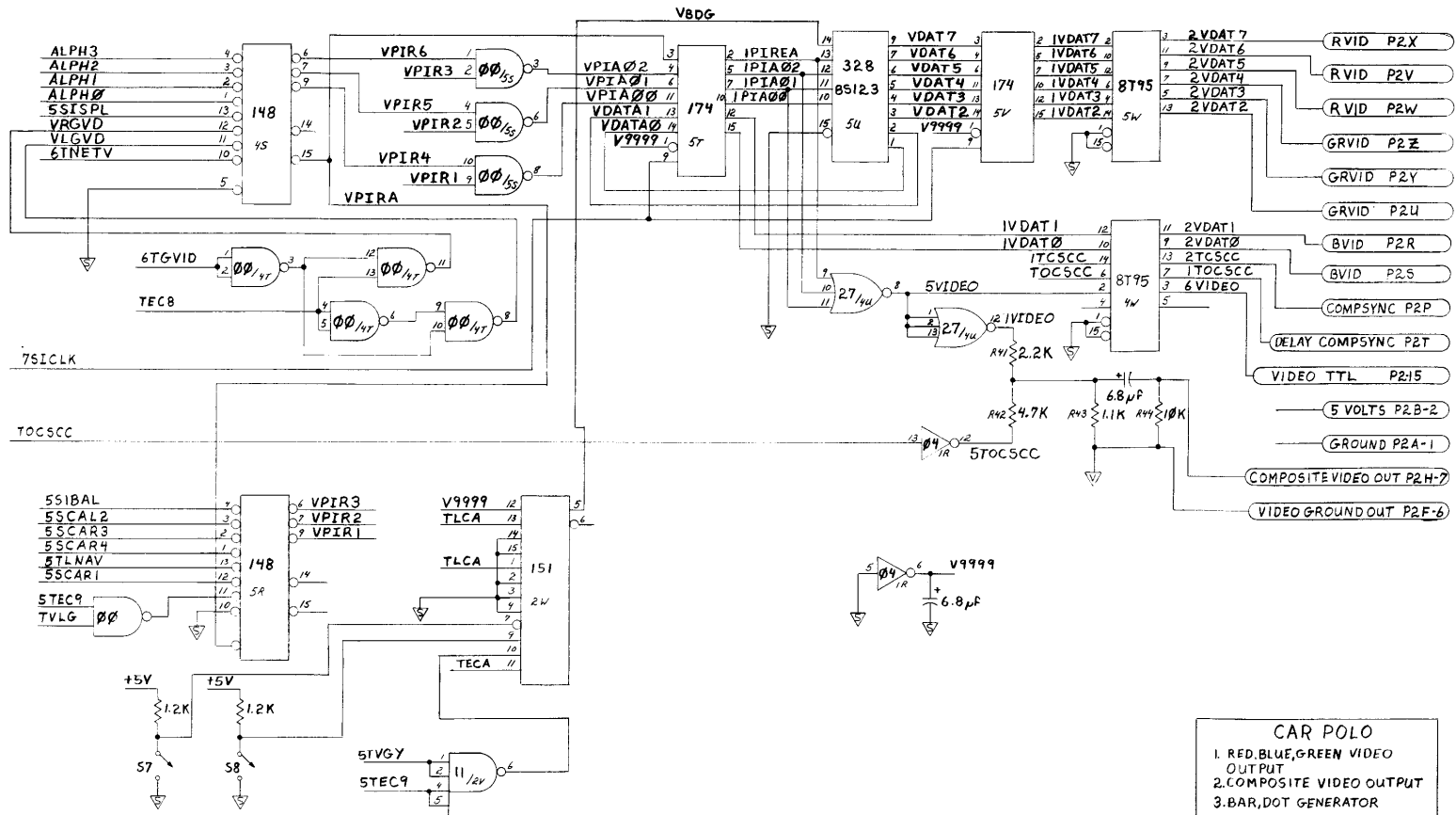

CAR POLO
 1. RED, BLUE, GREEN VIDEO OUTPUT
 2. COMPOSITE VIDEO OUTPUT
 3. BAR, DOT GENERATOR
 V.
 EXIDY, INC 1977

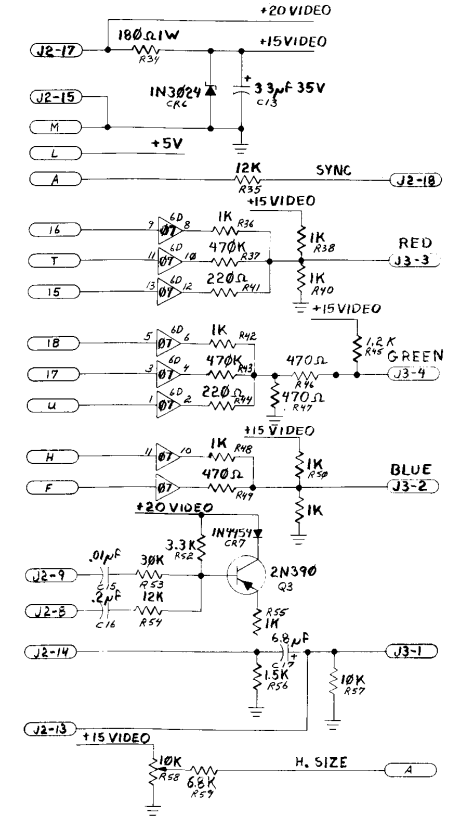
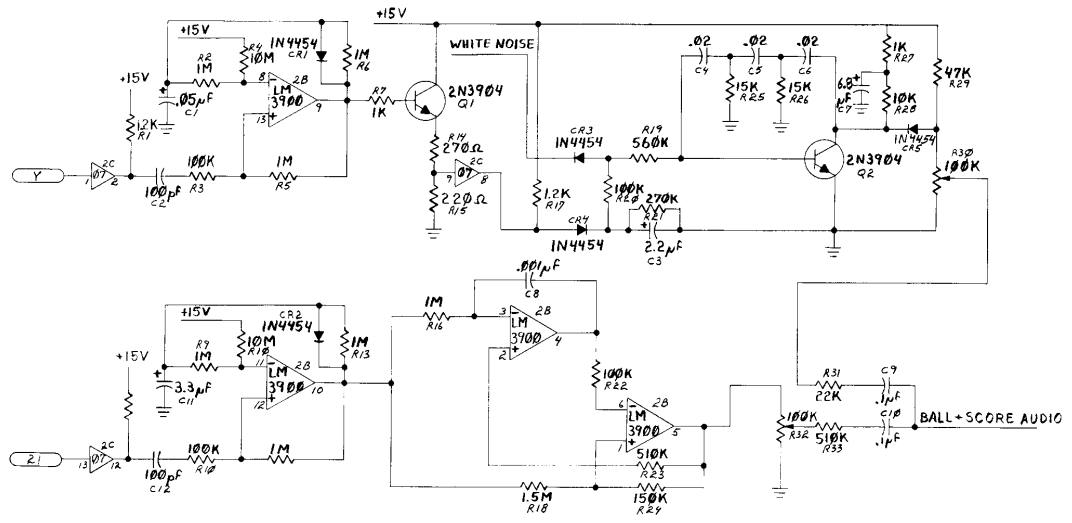

CAR POLO
 1. G.E. TV INTERFACE
 2. BALL AUDIO
 3. SCORE AUDIO

W.

EXIDY INC 1977

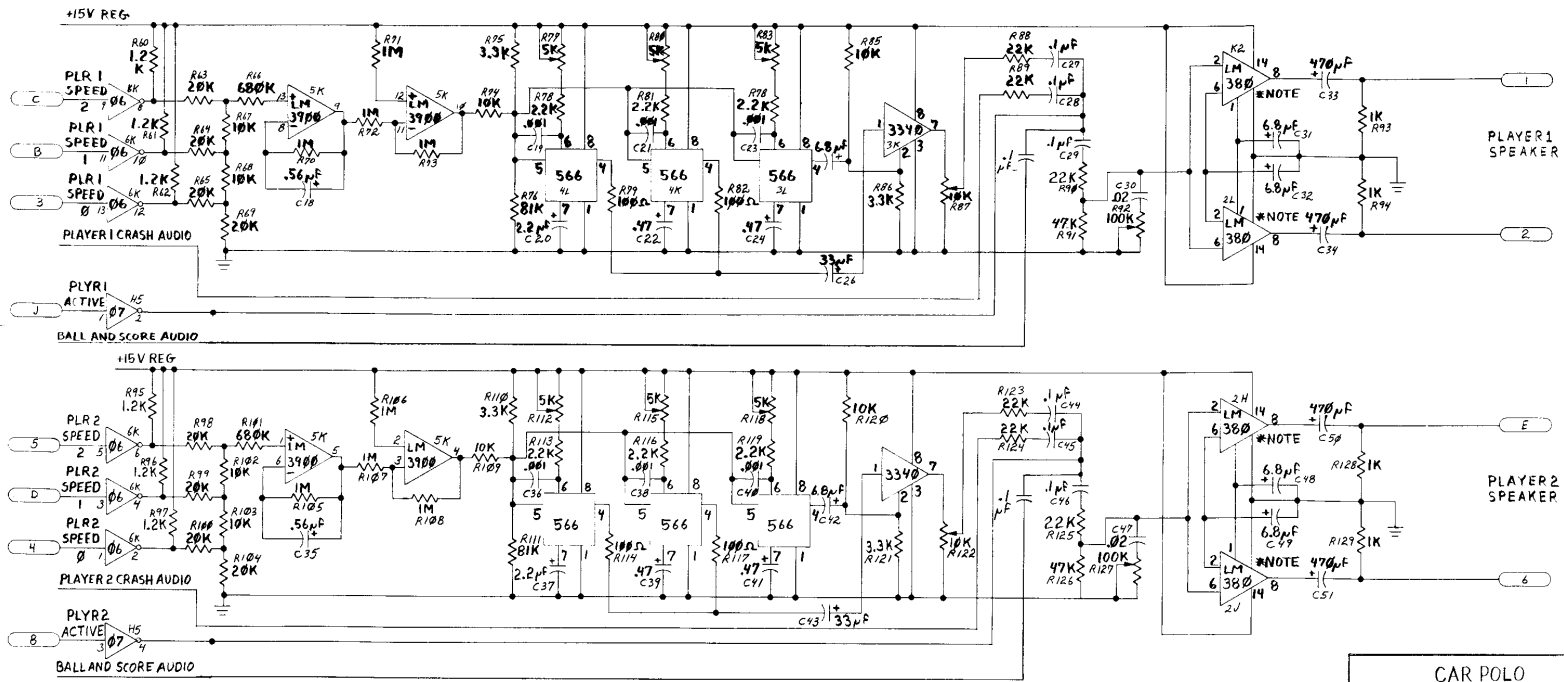

CAR POLO

1. MOTOR NOISE GENERATION
2. AUDIO SUMMING
3. AUDIO AMPLIFIERS

X.

EXIDY INC 1977

*NOTE: PINS 3,4,5,9,10,11,12,+13 ARE ALL TIED TOGETHER

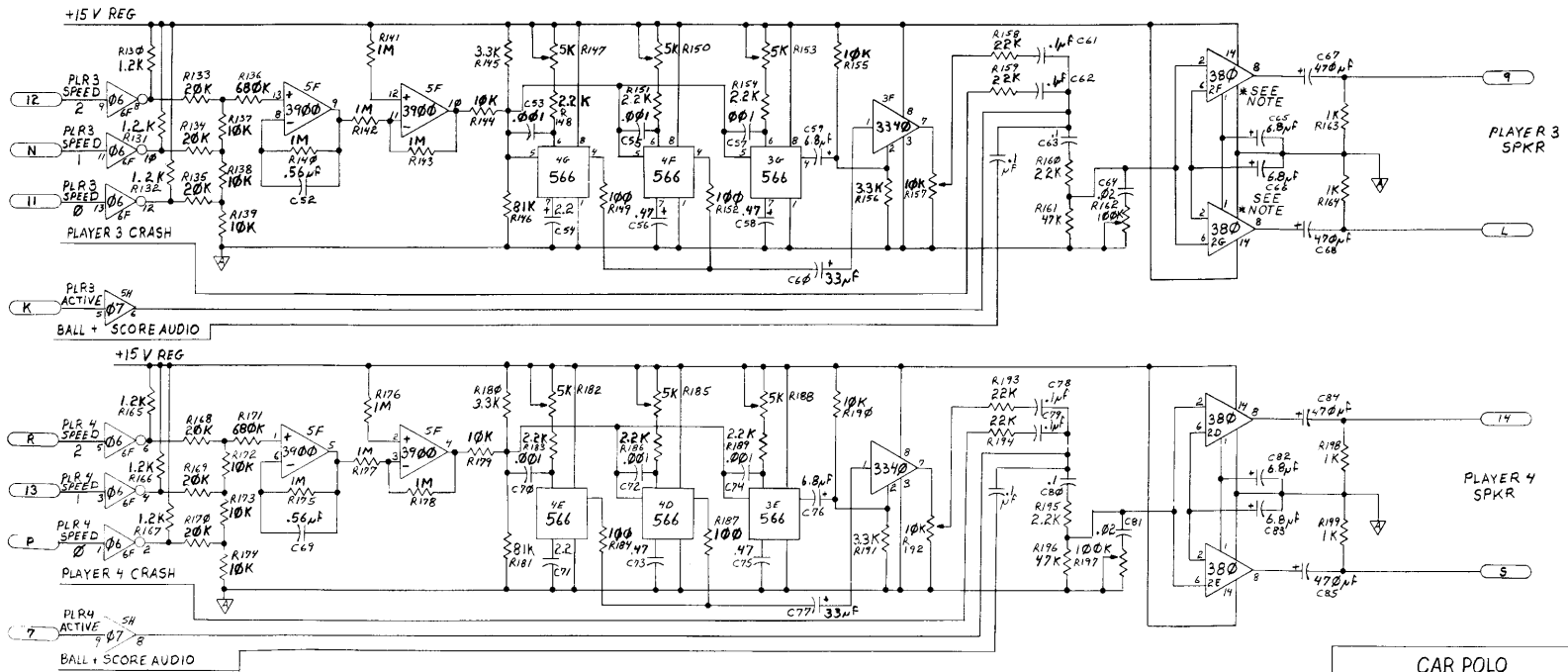

CAR POLO

1. MOTOR NOISE GENERATION
2. AUDIO SUMMING
3. AUDIO AMPS

Y.

EXIDY INC. 1977

NOTE: PINS 3, 4, 5, 9, 10, 11, +13 ARE ALL TIED TO GROUND

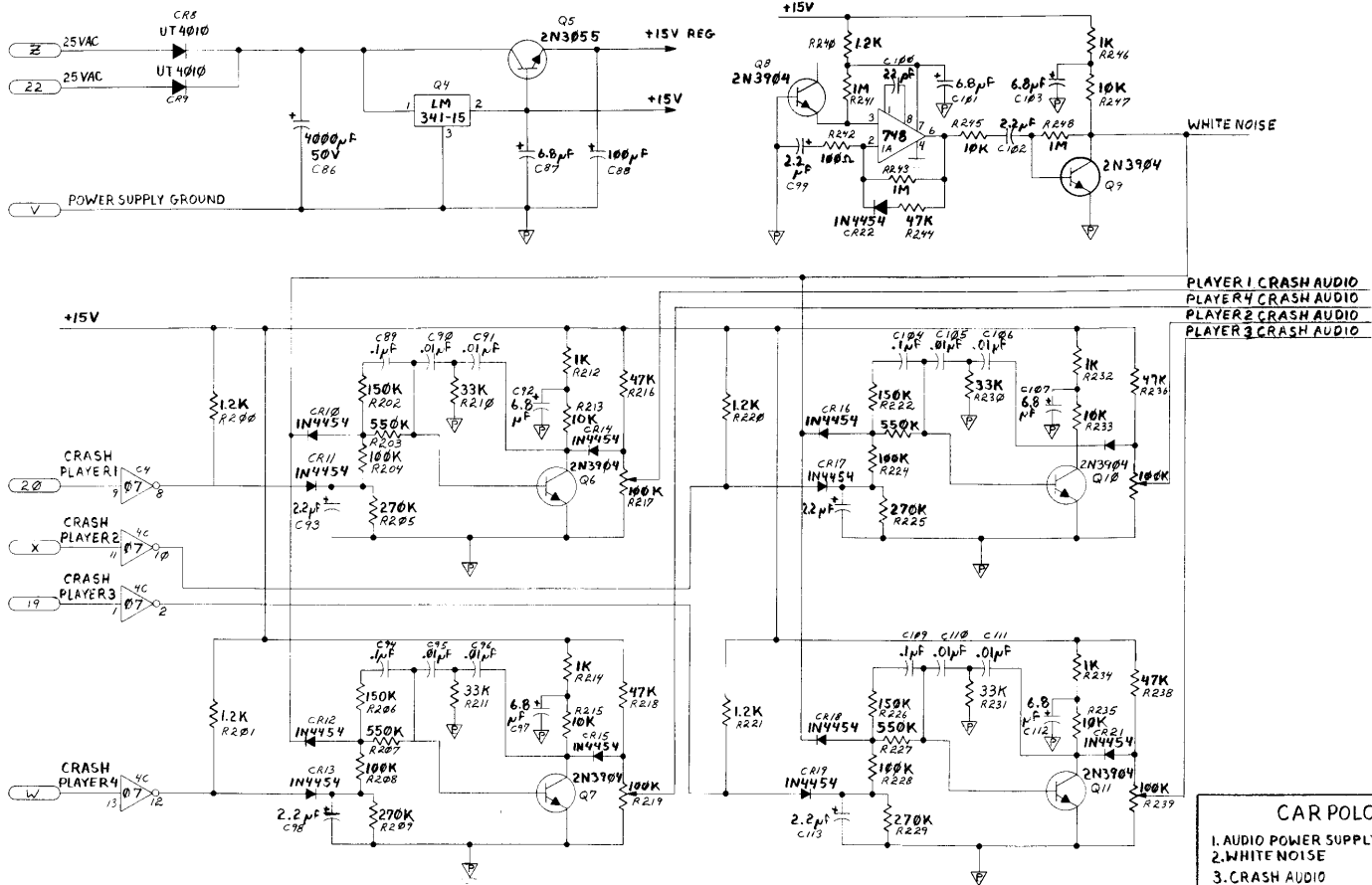

CAR POLO
 1. AUDIO POWER SUPPLY
 2. WHITE NOISE
 3. CRASH AUDIO

Z.